



COMPANION

Achievement Class



Youth Ministries Department of the Seventh-day Adventist® Church

Curriculum
Requirements &
Developed Resources



Copyright © 2013 by the Youth Ministries Department of the Seventh-day Adventist® Church
www.gcyouthministries.org.

Design and layout: Isaac Chía & Alexandra Mora

Printed in the United States of America

All rights reserved. No part of this publication may be reproduced, stored in a retrieval system, or transmitted in any form or by any means—electronic, mechanical, digital, photocopy, recording, or any other—except for brief quotations in printed reviews, without the prior permission of the publisher.

Rights for publishing this book outside the U.S.A. or in non-English languages are administered by the Youth Ministries Department of the Seventh-day Adventist® Church. For additional information, please visit our website, www.gcyouthministries.org, email Youthinfo@gc.adventist.org, or write to Youth Ministries Department, General Conference of Seventh-day Adventists® Church, 12501 Old Columbia Pike, Silver Spring, MD 20904, U.S.A.

CONTENTS

Objectives	4
Aim, Motto, Pledge & Law	5
How to Use the Instruction Plans	6
Annual Program	7
Requirements	9
Requirement Details	
General	10
Spiritual Discovery.....	13
Serving Others	25
Friendship Development	28
Health and Fitness	29
Organization and Leadership Development	34
Nature Study	39
Outdoor Life.....	47
Lifestyle Enrichment	61

OBJECTIVES

- To provide opportunities for the juniors to learn that God loves and cares for all people.
- To help them to realize that Christ is the greatest revelation of God.
- To encourage an awareness within the juniors that the church is interested in them as individuals.
- To allow for personal growth and development through interpersonal relationships within selected activities.
- To enlarge their vision of the needs of their community and to help them find ways of attending to these needs.
- To assist them in developing a desire for achievement in all their work, and to stimulate a desire to continue through the entire class program.

AIM, MOTTO, PLEDGE & LAW

AIM

The Advent Message to All the World in My Generation.

MOTTO

"The love of Christ constrains me."

PLEDGE

By the grace of God,
I will be pure and kind and true.
I will keep the Pathfinder Law.
I will be a servant of God and a friend to man.

PATHFINDER LAW

The Pathfinder Law is for me to:

1. Keep the morning watch.
2. Do my honest part.
3. Care for my body.
4. Keep a level eye.
5. Be courteous and obedient.
6. Walk softly in the sanctuary.
7. Keep a song in my heart.
8. Go on God's errands.

HOW TO USE THE INSTRUCTION PLANS

To assist class instructors in the work of organizing the curriculum into an instruction plan, you will find included a comprehensive **suggestion** on how to go about designing and completing this work in one year using 30 to 35 minute class periods. When organizing your plan, remember that the Pathfinder year generally follows the school year. In some countries this means that only part of the year is available for meetings, while other countries are not restricted this way, but to accommodate all schedules this plan is based on a minimum of a 20 week schedule. Those clubs with more time are encouraged to adjust the following plan accordingly.

Most conference youth departments conduct three combined events such as rallies, fairs, and camporees each Pathfinder year. While the instruction plans are organized so that there is no work for the Pathfinder to complete on days that they are on campouts or at conference events, several requirements do lend themselves to these actions and may be completed at those times.

Bi-monthly outings are often encouraged by the conference, and instructors should try to maximize the use of these times. For further details on bi-monthly outings, see the Pathfinder Staff Manual.

PLEASE NOTE: These plans are **suggestions** only. By all means modify or adapt them to suit your own situation, resources, and capabilities.

ANNUAL PROGRAM

WEEK	SAMPLE SCHEDULE	REFERENCE PAGE
1	Pledge - Discuss meaning, illustrate and learn	11
	Identify and describe 12 birds	16
	Introduce The Happy Path	16
	Introduce Book Club reading	11
	Membership and Dues	
2	N.T. books -Discuss and begin learning	11
	Begin reading Matthew and Mark.	42,16
	Physical fitness and exercise - healthful living	61
	Introduction and Memory Gems	18,19
3	Review N.T. Books	18
	Identify and describe 12 trees	62
	Plan a campout, hike, or party	38
4	Quiz on N.T. books	18
	Points on campsite selection	62
	Plan to attend 5 Day Plan or make poster, etc.	50
5	Campout	64
	Review N.T. books	18
	Build fires, know uses, safety rules/ 8 km Hike	72
6	1 Cor. 9:24-27 - explain and learn	18
	National Flag - composition and proper use	16
	Check reading of Matthew and Mark	16
7	Creation Story Log	88
	Review birds and trees	60
8	Effects of smoking	43
	Introduce Nature Honor (This will continue for several sessions.)	
	Review 1 Cor. 9:24-27	
	Introduce Arts & Crafts Honor	
9	Campout	24
	Review I Cor. 9:24-27	81
	Eight general directions without compass	77
	Review Friend Knots	53
10	Introduce Bible discussion-set homework	31
	Companion Knots	77
11	Results of Bible homework, discussion etc	24
	Plan Community service	18
	Knots/ knot board with 15 knots	66

WEEK	SAMPLE SCHEDULE	REFERENCE PAGE
12	Bi-monthly – 8 km hike and keep a log	26
	Review birds/trees	48
13	Assign reading of Ellen White's First Visions	66
	Nature Honor	61, 84
14	Bible memory sections	39
	Discussion results of Community Service	35
	Check all reading work	37
15	Campout	18, 19
	Review Bible memory section	
	Cook a camp meal without utensils	24
	Discuss cultures, gender	43
	Complete Arts and Crafts Honor	54
16	Discuss how God uses prophets	26
	First Aid	35
	Household Arts, etc.	
17	Complete Crossword puzzle	22
	Complete First Aid – Test	
	What Parents provide	
18	Bi-monthly Advanced Beginner's Swimming Honor (Caution: this may require special sessions)	45
19	Memory Gem Exam	30
20	Check all home assigned work. Complete unfinished work.	83
	Review memory section – complete honors	40
	Plan Investiture Program	

COMPANION REQUIREMENTS

GENERAL

1. Be 11 years old and/or in grade 6 or its equivalent.
2. Be an active member of the Pathfinder Club.
3. Learn or review the meaning of the Pathfinder Pledge and illustrate its meaning in an interesting way.
4. Read the book *The Happy Path* or similar book on the Pledge and Law if not previously read.
5. Have a current Book Club Certificate and write at least a paragraph of review on one book of your choice.

ADVANCED

1. Know the composition and proper use of your national flag.

SPIRITUAL DISCOVERY

1. Memorize the New Testament books and know the four areas into which the books are grouped. Demonstrate your ability to find any given book.
2. Hold a current memory gem certificate.
3. Choose, in consultation with your leader, one of the following areas:
 - a. One of Christ's Parables
 - b. One of Christ's Miracles
 - c. Sermon on the Mount
 - d. Second Advent Sermon
 and show your knowledge of what Christ taught in one of the following ways:
 - a. Discussion with the leader
 - b. Group activity
 - c. Giving a talk
4. Read the Gospels of Matthew and Mark in any translation. Commit to memory any two of the following:
 - a. Beatitude (Matthew 3:3-12)
 - b. Lord's Prayer (Matthew 6:9-13)
 - c. Christ's Return (Matthew 24:4-7, 11-14)
 - d. Gospel Commission (Matthew 28:18-20)

ADVANCED

1. Read about Ellen White's first vision and discuss how God uses prophets to present His message to the church.
2. Complete the crossword puzzle on the first vision of Ellen White.

SERVING OTHERS

1. By consultation with your leader, work out ways to spend at least two hours in your community, demonstrating in a consistent manner real companionship to someone else.
2. Spend at least a half day participating in a project that will benefit the community or your church.

ADVANCED

1. Participate in an outreach activity and bring a non-SDA friend to participate or observe.

FRIENDSHIP DEVELOPMENT

2. Discuss the principle and demonstrate the meaning of respect for people of different cultures and gender.

ADVANCED

1. Discuss and demonstrate respect for your parents/guardian and what they provide for you.

HEALTH AND FITNESS

1. Memorize and explain 1 Cor. 9:24-27.
2. Discuss with your leader physical fitness and regular exercise as they relate to healthful living.
3. Learn about the detrimental effects of smoking on health and fitness, and write your own pledge of commitment to abstaining from the use of tobacco.
4. Complete the Advanced Beginner's Swimming Honor.

ADVANCED

1. HIV/AIDS curriculum
2. Attend a Five Day Plan, **or** view two films on health, **or** make a poster on smoking **or** drug abuse, **or** help prepare a display on tobacco for a show, etc.

ORGANIZATION AND LEADERSHIP DEVELOPMENT

1. Plan and lead a devotional service for your group.
2. Help your unit or club plan a special activity such as a party, hike, or overnight campout.

ADVANCED

1. Participate in a special club event such as an investiture, open house, induction, or Pathfinder Sabbath, and then evaluate the event to determine how it can be improved.

NATURE STUDY

1. Participate in nature games **or** participate in a one hour nature walk.
2. Complete one of the following honors: Amphibians, Birds, Livestock, Poultry, Reptiles, Shells, Trees, or Shrubs.
3. Review the study of creation, and keep a seven day outdoor log of your personal observations from nature in which each day focuses on those parts that were created on that day.

ADVANCED

1. Identify and describe twelve birds in the wild and twelve native trees.

OUTDOOR LIFE

1. Find the eight general directions without the aid of a compass.
2. Participate in a two night campout. Know at least six points relative to the selection of a campsite.
3. Learn or review the Friend knots. Tie and know the practical use of the following knots: Sheet Bend, Sheepshank, Fisherman's Knot, Timber Hitch, Taut Line Hitch. Learn three basic lashings.
4. Pass a test in Companion first aid.

ADVANCED

1. Build five different fires and describe their uses. Discuss the safety rules in lighting fires, or hike eight kilometers and keep a log.
2. Cook a camp meal without utensils.
3. Prepare a knot board with at least fifteen different knots.

LIFESTYLE ENRICHMENT

1. Complete one Honor in Arts and Crafts not previously earned.

ADVANCED

1. Complete one Honor in Household Arts, Health & Science, Vocational, or Outdoor Industries not previously earned.

GENERAL

REQUIREMENT 1

Be 11 years old and/or in grade 6 or its equivalent.

EXPLANATION

1. When they are in Grade 6 or its equivalent.
 2. At the beginning of the semester in which their 11th birthday falls..
- New members may join on a quarterly basis or at any time that is suitable to your club.

REQUIREMENT 2

Be an active member of the Pathfinder club.

EXPLANATION

To be an active member, the junior should:

- a. Be a financial member of Pathfinders.
- b. Participate in at least 75 percent of all activities.

The junior should support Pathfinders with his influence and accept his share of responsibility as opportunity is given to him.

REQUIREMENT 3

Learn or review the meaning of the Pathfinder pledge and illustrate its meaning in an interesting way.

CLASS PERIODS: ONE

TEACHING METHOD

Juniors may illustrate the pledge segments by drawing, painting, or cutting out pictures. You may choose, however, to make this a class project. Have each junior choose a segment he/she would like to illustrate. At the conclusion, invite them to explain their illustration. Some may wish to use a skit or write a poem or music on the theme.

The Pathfinder Pledge

By the grace of God,
 I will be pure and kind and true.
 I will keep the Pathfinder Law.
 I will be a servant of God and a friend to man.

MEANING OF THE PLEDGE

“By the grace of God” means that I will rely on Him, realizing that His strength is made perfect in my weakness. It means that only as I rely on God can I do His will. It means that only through grace are we saved from our sins through the power of Jesus

Christ, our Savior and Redeemer.

- “I will be pure” means I will rise above the wicked world in which I live and keep my life clean with words and actions that will make others happy.
- “I will be kind” means that I will be considerate and kind not only to my fellow men, but to all of God’s creation as well.
- “I will be true” means that I will be honest and upright in study, work, and play and can always be counted on to do my very best.
- “I will keep the Pathfinder Law” means that I will seek to understand the meaning of the Pathfinder Law and will strive to live up to its spirit, realizing that obedience to law is essential in any organization.
- “I will be a servant of God” means that I pledge myself to serve God first, last, and best in everything I am called upon to be or do.
- “I will be a friend to man” means that I will live to bless others and do unto them as I would have them do unto me.

METHOD OF TESTING

Memorization and illustration.

REQUIREMENT 4

Read the book *The Happy Path* or a similar book on the pledge and law if not previously read.

EXPLANATION

This volume is written by Lawrence Maxwell and may be ordered from the local Adventist Book Center. It may be read individually or as a class project. It is a detailed explanation of the pledge and law in story form. If it was read for the Friend requirement, this requirement has been taken care of.

REQUIREMENT 5

Have a current book club certificate and write at least a paragraph of review on one book of your choice.

EXPLANATION

The Book Club selections are chosen to give the candidate a well-rounded reading program of adventure, nature, biography, and inspirational stories. A “current” certificate for the class means for the church year in which one completed the work for investiture. A Book Club certificate reported for any class may not be used a second time for any other class. When a junior has completed reading the Book Club selections, his/her name should be forwarded by the leader to the local conference office youth department, which will issue a Book Club Certificate.

METHOD OF TESTING

A verbal report of the book titles, and at least one paragraph of review on one of these books.

ADVANCED REQUIREMENT 1

Know the composition and proper use of your national flag.

CLASS PERIODS: ONE

EXPLANATION

It is necessary to understand the history of the national flag and proper flag etiquette.

FLAG ETIQUETTE

It has not always been the privilege of the individual to fly his country's flag. On land, during the Middle Ages, banners were flown from forts, and as colonization swept forward, the flag was flown as a symbol of possession. It was always the state or its representatives that hoisted the flag. The flag was not really the property of the people.

The desire on the part of the individual to hoist his country's flag as an expression of his patriotism started in most countries after the Napoleonic Wars, and although many reigning monarchs tried to stop this development, their efforts were in vain. In a few countries, it is still completely forbidden to fly flags privately.

In most countries, rules and regulations have been formulated for private flag flying. On land these rules vary from country to country, but on sea strict rules have been developed and these are accepted everywhere. A country's national flag has now become an honored symbol.

SPIRITUAL DISCOVERY

The purpose of the Spiritual Discovery section is to familiarize the junior with the New Testament and to help him to understand the meaning of some of Christ's teachings.

REQUIREMENT 1

Memorize the New Testament books and know four areas into which the books are grouped. Demonstrate your ability to find any given book.

CLASS PERIODS: ONE

OBJECTIVE

To help the Companion become acquainted with the location of the books of the New Testament.

TEACHING METHODS

Repetition and association are among the best methods of memorization. Following are five ways to assist you in teaching this requirement:

1. Memory Chart
2. Media Report
3. Bible Sword Drill
4. Learn the Books of the Bible to Music
5. Book Shelves

1. Memory Chart

Copy the memory chart onto a blackboard or duplicate the material and give it to the class. After discussion, the books of the New Testament can be learned in their various sections.

MEMORY CHART

Matthew
Mark
Luke
John

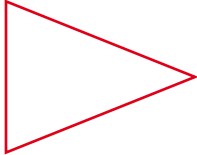

4 Gospels

Acts



1 History

Romans
I Corinthians
II Corinthians
Galatians
Ephesians
Philippians
Colossians
I Thessalonians
II Thessalonians
I Timothy
II Timothy
Titus
Philemon
Hebrews

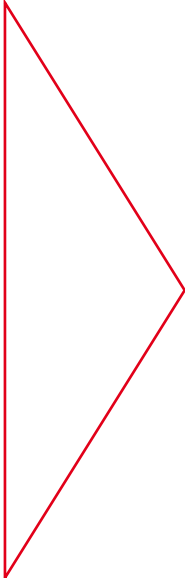

By Paul

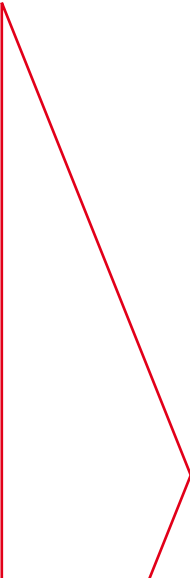

21 letters

James
I Peter
II Peter
I John
II John
III John
Jude

Revelation



1 Prophecy

2. Media Report

Choose one New Testament author and either:

- a. Write a brief newspaper report
- or
- b. Record a radio style interview on how and when he met Jesus the Great Teacher. Identify the books the author wrote.

Some points to consider:

- What kind of person were you before you met Jesus?
- Occupation?
- Where you met?
- How did He teach you?
- What was your reaction?
- Why and what did you write?

3. Bible Sword Drill

This is a group activity to give the Companions practice in locating the books of the New Testament quickly. Ephesians 6:13-17 describes the Christian "armor" of which the Sword is the Word of God (verse 17).

Operation

1. Select participants:
 - a. Two Companions to hold the rope
 - b. As many participants as desired
2. Participants will form one straight line behind a rope held immediately in front of them approximately 50 cm from the floor. Their Bible is to be held (sheathed) under their left arm.
3. Leader will give the commands: "ATTEN-TION" "DRAW SWORDS" Companions quickly bring their right hand across their body - draw their sword (Bible) and hold it in front of them, closed, waist high, ready to find the reference.
4. Leader announces the reference, e.g. "The Book of Mark" (begin with the well-known books), or ask for a book from one of the sections, e.g. Gospels, Letters. The exercise becomes more difficult as you call the smaller books or ask for specific chapter and verse.
5. No Companion moves until the order is given: "CHARGE." The rope is dropped to their feet while the Companions quickly find the reference. Immediately when the reference is found, they take one pace forward, keeping one hand on the open page of the Bible.
6. A ten second time limit is given from the command "CHARGE" to find the reference and step one pace forward. (Vary the time limit to suit the experience of your group.)
7. The time keeper will call "TIME" as the time limit expires. The rope will immediately be raised, perhaps catching some Companions part way across. They should return behind the line.
8. Each participant who steps across the line before the time limit is reached is a winner.
9. An appointed judge will inspect the references.
10. An award of two points can be given to each winner. See who is the first to get to twenty.
11. Leader shall call "ONE PACE BACKWARD MARCH." Rope keepers shall lower the rope and raise it again after the Companions have crossed it.
12. Leader shall call "SHEATH SWORDS." Companions quickly tuck their Bibles under their left arm and return right hand to their side.
13. Ready now to repeat activity from "DRAW SWORDS."

Personnel

1. Leader - gives commands; prepares references before the meeting.
2. Two people to hold and drop the rope.
3. Two judges. One to watch the crossing of the rope, especially those who only get halfway when "TIME" is called. Second judge to check accuracy of references.
4. Time keeper, who with stop watch or second hand on wrist watch, calls "TIME."
5. Score keeper to keep track of scores.

4. Learn the Books of the Bible to Music

Happy Songs for Boys and Girls, No. 115, available from the ABC. Or the following books of the Bible can be sung to the melody of "Battle Hymn of the Republic."

Verse 1 Gen-es-is & Ex-od-us, Le-vit-ic-us & Num-bers,
Deut-er-on-omy, Josh-ua, Jud-ges, Ruth & Samuel.
Kings, Chronicles, Ez-ra, Neh-em-i-ah, Es-ther, Job, Psalms.
Pro-verbs, Ec-clesi-as-tes.

Verse 2 Song of Solomon, I-sai-ah, Jer-e-mi-ah, Lam-en-ta-tion,
Ezek-iel, Dan-iel, Hose-a, Jo-el, Am-os, Oba-diah.
Jo-nah, Mi-cah, Na-hum, Hab-ak-kuk & Zeph-an-I-ah,
Hag-gai, Zech-ariah, Mal-a-chi.

Verse 3 Matthew, Mark, Luke, John, Acts, Ro-mans, Cor-in-thi-ans,
Gal-atians, Ephesians, Phil-ippians, Col-oss-ians, Thes-sa-lo-ni-ans,
Tim-othy, Ti-tus, Phil-emon, He-bre-ws, James & Pe-ter.
John, Jude, Rev-e-la-tion.

5. Book Shelves

Have cartons or blocks of wood with names of the books of the Bible printed clearly on the narrow edges. If possible, place them on book shelves.

- a. Mix them up and have juniors sort them into correct order.
- b. Empty shelves completely, and have juniors put them in the shelves in order.
- c. Do either of the above, using a stop watch to time them.

RESOURCES

Bible Books by Zondervan, available from the ABC.

METHOD OF TESTING

1. Be able to repeat the books in order,
OR
2. The leader conducts a Bible drill game in which the Companion is required to find fifteen New Testament books in two minutes.

REQUIREMENT 2

Hold a current memory gem certificate. Below is provided a suggested list to choose from should your local youth department not have a recommended list.

One text from each of the seven categories may be selected to memorize.

1. Great Passages	
	Ps. 119: 11
	Isa. 43: 12
	Matt. 28:19,20
	Luke 5:15
	Option

5. Doctrine	
	Eph. 1:8-10
	Deut. 6: 5
	Acts 2:38
	Option

2. Salvation	
	John 1:1-3, 14
	Luke 19:10
	Ps. 103:10-12
	Isa. 53: 5
	Eph. 3:20, 21
	Option

6. Prayer	
	Ps. 34:3-4
	Matt. 6:6
	1 Peter 1: 3
	1 John 4:7
	Option

3. Relationships	
	Isa. 1: 18
	John 1:12-13
	1 Tim. 6:6-8
	1 John 3:17
	Acts 17:26, 27
	Option

7. Promises/Praise	
	Ps. 56; 35:7
	Ps. 37:3
	Isa. 35:10
	James 4:7, 8
	1 John 2: 17
	Option

4. Behavior	
	1 Sam. 15:22
	Rom. 12:1-2
	1 Thes. 5:15
	Eccl. 9:5-10
	Luke 2:51, 52
	Option

CLASS PERIODS: ONE

Of the total class periods allocated for the Companion Course, one is set aside for the Memory Gem Examination.

OBJECTIVE

To provide opportunity for text memorization leading to spiritual growth through personal application of the memory gem.

TEACHING METHODS

1. Each child can make up an art folder with the texts recorded and illustrated with pictures from magazines, etc. to be done during the week as a regular project at home.
2. In addition to learning the memory gem, each child can bring a picture that illustrates the text so that a poster can be made up from the group collection each week. Posters can then be used to decorate the meeting place.
3. Encourage the junior to learn the memory gem as part of his daily worship.
4. Recite memory gems as a voice choir.

Suggestions for the Weekly Review of the Memory Gems:

1. **Repetition Review.** After having a few juniors say the verse for the day, call on all to say it together, then all the girls, then the boys, then perhaps the teachers. Close by having all say it together, and see if all can take part. If possible, continue until they can. (Always have reference repeated each time the verse is said.)
2. **Missing Word Review.** Write text clearly on board before meeting, and rub out about every second word, particularly any catch ones, and usually the first one, which is not always easy to remember. Ask different ones to supply the missing words, requesting that only the one asked should respond. In small groups, members might be asked sometimes to come up and write in the word.
3. **Competition Review.** When there are about equal numbers of girls and boys, draw a line down center of the blackboard, heading sides respectively GIRLS - BOYS. Then put a mark for each one who correctly recites the verse for the day, under the proper heading, and see which side will win.
4. **Word Review.** Have text repeated by two or three, or by all together once or twice, then ask for each one in rows to repeat the following word without hesitancy. Then move about from one to another, pointing to the one you wish to supply the word. Only the one to whom you point should respond, but pass on fairly quickly so that the review will be brisk and interesting.
5. **Question Review.** Ask as many questions as you can on the text being studied. In some instances two or three questions can be asked on one text, but mix them among questions on other texts. If possible, request that answers be given in the exact words of Scripture.
6. **Text Bee Review.** Divide the group in about half. Then have members of one side call for a text or ask a question of a member on the other side. If answered, that side does the asking, if not, the same side asks again. (Conduct something after the style of a spelling bee.)
7. **Surprise Reviews.** Have references to date written clearly on different slips of folded paper. Give one to each member before the meeting, asking them not to open until asked to do so. For review, call names one by one, ask them to rise, open slip, and say the verse called for. The reference should be read aloud so that all can determine if the right text is quoted.
8. During another period, write out the texts on slips of paper, as in No. 7, and have the references given in same way.
9. **Reference Test.** Put on blackboard something like the following:

_____ 29: 11	Psalm ____: 8
Isaiah ____: 12	Timothy 5: ____
_____ 11: ____	_____ : 58

Ask different ones to fill in as for "Missing Word" review.
10. **Written Test.** Before the meeting, put two or three questions on the board in clear script and hand out paper and pencil. Reveal questions on the board and ask all to try and answer them. Tell them it is not an examination, and that each person will correct his or her own answers.
11. **Thought Review.** Put a thought from each verse on the board and ask members to tell which texts contain these thoughts or statements.
12. **Bible Study Review.** Devote a meeting to full Bible Study review. This could be worked up in the form of a dialogue, or delivered as a study by one or more members of the group, the remaining members, or a few specially chosen ones to form the audience. These could be encouraged to ask questions, which would be possible to answer with the texts learned.

RESOURCE

Remembering Bible Texts for Children, Publisher: Scripture Union. Available from Christian book stores.

METHOD OF TESTING

Pass Memory Gem test provided by the conference youth department.

REQUIREMENT 3

Choose **one** of the following areas in consultation with your leader:

a. One of Christ's Parables; **b.** One of Christ's Miracles; **c.** Sermon on the Mount; **d.** Second Advent Sermon

And show your knowledge of what Christ taught in **one** of the following ways:

a. Discussion with the leader; **b.** Group activity; **c.** Giving a talk

CLASS PERIODS: TWO

OBJECTIVE

To help the Companion share in the creative teaching methods of Jesus.

TEACHING METHODS

1. Discussion with your leader. To make it easier for the Companions to discuss their chosen subject with you, we suggest one of the following:
 - a. Have each Companion make up their own time line or picture project, which in turn is to be explained verbally to the teacher.
 - b. Make up a chart to illustrate Christ's Second Advent sermon using a collection of old newspaper headlines. Each headline should be supported by an appropriate part of Matthew 24 or Mark 13.
2. Group Activities
 - a. Role Play. As a group, the Companion class may like to act out the topic they have chosen, with each person making up their own lines and costumes.
 - b. Divide the class up into small groups, and for:
 - 1) The Prodigal Son, make up a mural depicting:
 - the farm and house he left
 - where he went and what he did
 - where he ended up
 - the home coming

When the mural is completed each junior can explain what his part of the mural means.
Conclude with a film on the subject.
 - 2) Second Advent Sermon:
 - Divide the class into groups and make up a time line.
 - Each member of the class explains his part of the time line.
 - Screen a film on the subject such as "Time of Fury".

3. Reproduce the following discussion guide for each class member. After they have read it through and made their choices, spend time as a group exchanging reasons for the choices they made. This is a values clarification exercise.

IT HAPPENED AT THE WEDDING

"On the third day there was a wedding at Cana-in-Galilee. The mother of Jesus was there, and Jesus and His disciples were guests also. The wine gave out, so Jesus' mother said to Him "They have no wine left." He answered, "Your concern, mother, is not mine. My hour has not yet come." His mother said to the servants, "Do whatever he tells you." There were six stone water-jars standing near, of the kind used for Jewish rites of purification; each held from twenty to thirty gallons. Jesus said to the servants, "Fill the jars with water," and they filled them to the brim. "Now draw some off," he ordered, "and take it to the steward of the feast", and they did so. The steward tasted the water now turned into wine, not knowing its source, though the servants who had drawn the water knew. He hailed the bridegroom and said, "Everyone serves the best wine first, and waits until the guests have drunk freely before serving the poorer sort, but you have kept the best wine till now" (John 2:1-11, NEB)

STUDENT QUESTIONNAIRE

This deed at Cana-in-Galilee is the first of the signs by which Jesus revealed His glory and led His disciples to believe in Him.

- If I had been at the wedding when Jesus turned the water into wine, I would have been: (Circle one)
 - suspicious
 - shocked
 - skeptical
 - delighted
 - amazed
 - intrigued
 - overwhelmed
- My guess as to the reasons why Jesus turned the water into wine is as follows:
 - He wanted to get the wedding party out of an awkward situation.
 - He wanted to make His mother happy.
 - He wanted to demonstrate His power.
 - He wanted to bring more joy to the wedding occasion.
- Circle the statement that brings out the real meaning of this story for you:
 - Jesus can turn something ordinary into something special.
 - When Jesus gives the instructions, do whatever He tells you.
 - For Jesus, nothing is impossible.
- The place in my life where I need to see a miracle is in my: (circle one)
 - Home life
 - Personal development
 - Future
 - Devotional life
 - Friends
 - School

METHOD OF TESTING

Participation in discussion, group activity, or talk.

REQUIREMENT 4

Read the Gospels of Matthew and Mark in any translation. Commit to memory any **two** of the following:

- | | |
|-----------------------|-----------------------|
| a. Beatitudes: | Matthew 5:3-12 |
| b. Lord's Prayer: | Matthew 6:9-13 |
| c. Christ's Return: | Matthew 24:4-7, 11-14 |
| d. Gospel Commission: | Matthew 28:18-20 |

CLASS PERIODS: ONE

Encouragement for learning and the testing is to be done in class. Reading and memory work is done out of class.

OBJECTIVE

To encourage Companions to form the habit of daily Bible reading and to memorize some of the important Bible passages for present and future benefit.

TEACHING METHODS

1. To make the reading of Matthew and Mark more meaningful, have each Companion work out a color code to distinguish between the varieties of methods that Jesus used when He taught the people. As they read the Gospels through, they can underline or color in the appropriate passages with the colors they have selected: e.g. Parables - red; Miracles - blue; Special Sermons - yellow; Promises - green.
2. Encourage the class to share with each other some of the important discoveries they have made during their reading.
3. The class may like to draw their own pencil sketches in the margin of the Bibles to indicate the various subject matter covered, e.g. loaves and fishes, boat in a storm, lame man, empty tomb. etc.
4. Have the class make a log of their reading of Matthew and Mark. They should set out clearly a daily log, including the date, plus the passage read for that day, e.g. May 24--Matthew 19:1-30; May 25--Matthew 20:1-34.

METHOD OF TESTING

Completion of reading Matthew and Mark and memory work.

ADVANCED REQUIREMENT 1

Read about Ellen White's first vision and discuss how God uses prophets to present His message to the church.

CLASS PERIODS: TWO

OBJECTIVE

To help the Companion to understand God's guidance in the establishment of the Seventh-day Adventist Church and its missions.

TEACHING METHODS

Ellen's first vision is written up in Early Writings, pages 13-20. The material provides excellent food for discussion and thought, especially for a Friday night devotional vespers.

There is a video series produced by the South Pacific Division and promoted by the White Estate (available through the Adventist Book Centers) entitled "Keepers of the Flame," which would make an excellent enrichment to this requirement.

Discussion could be carried out during unit devotionals as a panel or round table at any AY meeting or Sabbath school, etc.

STUDENT QUESTIONNAIRE

1. What does the term "Midnight Cry" mean to the Seventh-day Adventist Church?

2. What does Ellen's vision tell us about the 144,000?

1.

2.

3.

3. Who were two persons specifically identified as being saved and why were they not alive at the time of the vision?

- a.

- b.

- c.

4. List some of the activities we will be able to enjoy on the New Earth as seen by Ellen.

5. What was Ellen's reaction to all that she saw and how did she feel when the vision was over?

6. What did God tell you as a Pathfinder in that vision given so long ago?

ADVANCED REQUIREMENT 2

Complete the crossword puzzle on the first vision of Ellen White.

CLASS PERIODS: ONE

CROSSWORD

**on Ellen White's First Vision
as recorded in *Early Writings***

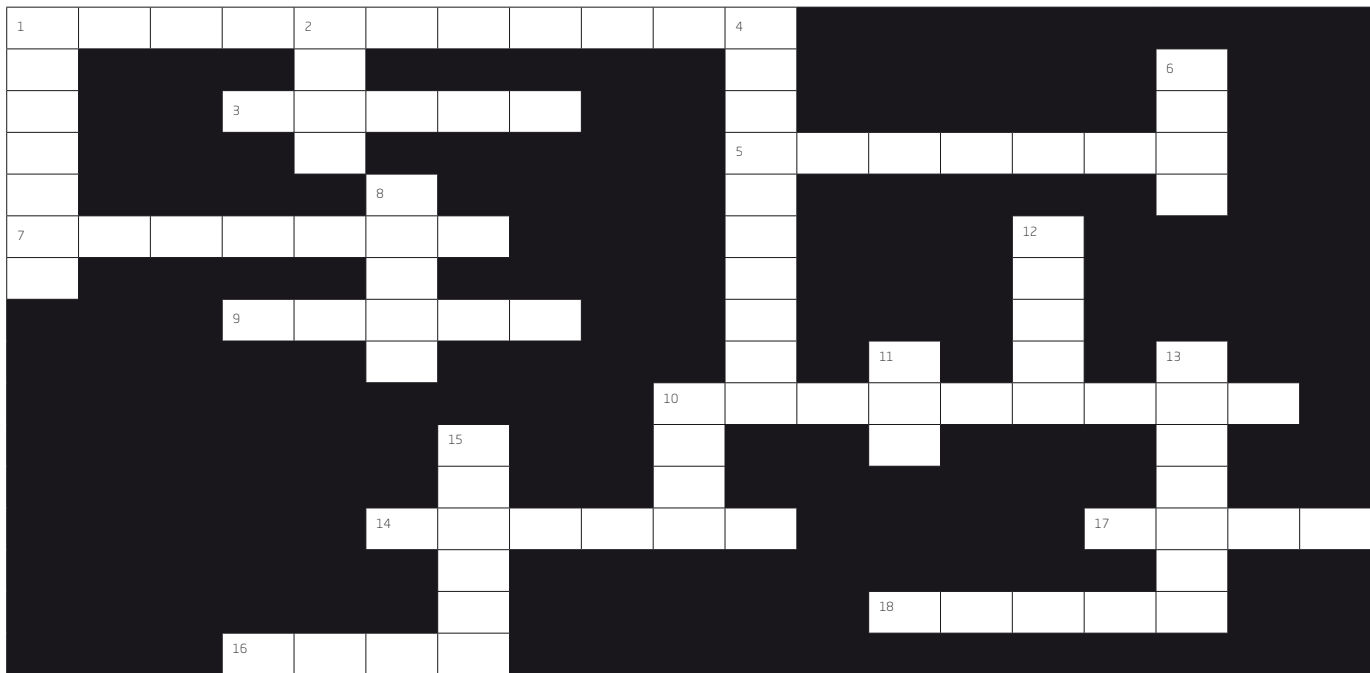
**DOWN**

- 1 Temple was supported by seven
- 2 Each received a harp of
- 4 Graves were opened by an
- 6 Straight and narrow
- 8 Rising far above
- 10 On their forehead with a new name
- 11 Border to their garments
- 12 Set up behind them
- 13 And lambs and wolves relax together
- 15 Brought back from heavenly

ACROSS

- 1 One of the trees near the temple
- 3 All stood on a sea of
- 5 In His left hand
- 7 Over the cloud
- 9 The table was many
- 10 How old Ellen was
- 14 Voice of God like many
- 16 One of the fruits on the table
- 17 How this world looked afterward
- 18 A small black

SERVING OTHERS

The purpose of the service section is to continue to provide opportunity for the Companion class to experience the joy and happiness of serving others.

REQUIREMENT 1

By consultation with your leader, work out ways to spend at least two hours in your community, demonstrating in a consistent manner real companionship to someone else.

CLASS PERIODS: ONE

OBJECTIVE

To help the juniors to understand and develop their possible casual friendships to the deeper level of companionship.

TEACHING METHODS

1. The companionship should be directed to someone in need such as shut-ins, disabled elderly, new-comers to the community, the shy and bashful of the same age, and the "difficult/left out" boy or girl.
2. The companionship can include little favors and inner circle group activities for the same age and extend to very meaningful areas for the elderly. Reading, letter writing, sharing and talking with an elderly person will be most significant.

METHOD OF TESTING

Participation in two hours of practical companionship. Have Companions give a report describing the effect or result of their activity on the people they shared with and describe how much they enjoyed this activity, if they learned anything, and if it was worthwhile.

REQUIREMENT 2

Spend at least a half day participating in a project that will benefit the community or your church.

CLASS PERIODS: OUT-OF-CLASS TIME

OBJECTIVE

To help the Companion develop an interest in helping others.

TEACHING METHODS

1. Activities can include a civic project that will necessitate a visit by the leader to the authorities to arrange for an approved project, e.g. clean-up campaign, etc.
2. The leader could also arrange with the pastor/church board for a church project that will benefit from their service. The church school can also be included as a beneficiary of the Companion's service.

Christian Services

1. Arousing interest in a community-wide recreation program for children, youth, and adults (hobbies, crafts, outdoor activities, hikes, intercultural festivals)
2. Working in institutions (typing, general work, leading games, crafts, playing the piano, assisting with children)
3. Conducting a quarterly program (or more often as needed)
4. Growing flowers to give away
5. Supplying reading materials to institutions
6. Helping harvest or gather perishable crops (glean)
7. Having a "Lord's Acre" project
8. Cooperating in a community survey
9. Supporting a community project (March of Dimes, etc.)
10. Working with juvenile delinquents
11. Visiting the jails and detention homes, etc.
12. Studying health-related problems in the community and organizing strategically to work on them
13. Encouraging citizens to vote
14. Participating in ecological improvement in the community
15. Sending youth teams to needy small churches
16. Food and clothing distribution
17. Babysitting
18. Senior citizen ministry
19. Repair jobs

Church Projects

1. Improve the church grounds.
2. Participate in church ministry committees.
3. Be an active member in the A Y organization.
4. Participate in church remodeling and equip a room.
5. Assist the pastor by distributing materials, flowers, making phone calls, running errands.
6. Issue invitations to strangers.
7. Visit shut-ins, do kind deeds such as reading and playing music. Take them to the store and get groceries.
8. Volunteer to drive cars to pick up shut-ins or others who could not otherwise attend. Baby-sit for parents to go to activities of the church.
9. Assist with secretarial work of the church.
10. Hold programs, services in institutions (nursing home, jail, etc.)
11. Write up stories of church events for local newspapers or church papers.
12. Keep the church building clean and attractive.
13. Care for church hymnals, Bibles, and church library.
14. Provide flowers.
15. Plant a garden for "give away" to the hungry.
16. Start a "collecting" library of historic items.
17. Assist in children's ministry i.e. storytelling, preparing equipment, gathering materials and caring for children.
18. Maintain fellowship with persons away from home.
19. Be faithful and help strengthen your youth group

20. Help maintain church vehicles and those of the aged.

METHOD OF TESTING

Participation in community or church project. Have Companions give a brief report on the actual project they were involved in and describe how it benefited the community.

ADVANCED REQUIREMENT 1

Participate in an outreach activity and bring a non-SDA friend to participate or observe.

OBJECTIVE

Involve the element of faith-sharing in a project or outreach ministry.

TEACHING METHOD

One of the above listed activities may be used in outreach ministry such as VBS, Five-day Plan, Revelation Seminar, etc. The non-SDA friend could be a prospective Pathfinder Club member.

FRIENDSHIP DEVELOPMENT

REQUIREMENT 1

Discuss the principle and demonstrate the meaning of respect for people of different cultures and gender.

CLASS PERIODS: ONE

OBJECTIVE

To develop a sense that under God there are no distinctions; we are all His children and are all equal: "no Jew nor Gentile, no slave nor free, no male nor female."

TEACHING METHODS

Some suggested activities:

1. Invite a foreigner to participate in a panel or special presentation.
2. Evaluate the practicality of the Golden Rule.
3. How do TV programs strengthen or weaken respect for others?
4. Role play positive relationships.

METHOD OF TESTING

Completion of activity.

ADVANCED REQUIREMENT 1

Discuss and demonstrate respect for your parents/guardian and what they provide for you.

CLASS PERIODS: ONE

OBJECTIVE

Life applications of the fifth Commandment

TEACHING METHODS

1. Role play a parent having to deal with a difficult junior.
2. Extend an invitation for a special presentation by someone in a juvenile court or police department.
3. Search for Bible stories that may apply and illustrate how they apply.

HEALTH AND FITNESS

The purpose of this section is to create an awareness that the body is the temple of God and to learn the harmful effects of smoking on health and fitness.

Three class periods have been allocated to teach this section.

REQUIREMENT 1

Memorize and explain 1 Corinthians 9:24-27.

CLASS PERIODS: ONE

OBJECTIVE

To give a biblical reason for temperate living.

TEACHING METHODS

1. To help the Companions memorize I Corinthians 9:24-27, provide paper or cardboard big enough for each verse to be written out and illustrated with either drawings or pictures. Explain to the class how Paul is using the Olympic Games as a symbol of health and fitness. Upon completion, each Companion has both written out and illustrated the texts, and he will have a set of aids to take home that will help him memorize the Scripture passage.
2. To make the work of temperance meaningful, have a special project for the class to engage in during the year. Here are a number of suggestions:
 - a. Periodic distribution of temperance literature: Apply to the church board through the health and temperance director for an appropriation of funds for the purchase of special tracts. Some of the literature available from the conference temperance department comes under the following titles:
 - "Effects of Alcohol on the Body"
 - "Drink Without Becoming Drunk"
 - "Is Moderate Drinking Harmful?"
 - "Nicotine Knock Out"
 - "You Can Overcome the Drink Habit"
 - "How to Stop Smoking"
 - "It Costs a Girl Too Much to Smoke"
 - b. Have a temperance bulletin board: Class members can bring in newspaper clippings on the subject of temperance and pin them on the board as a special project, e.g. road toll information, cancer and smoking, heart disease statistics, diet information, drunk driving charges, etc.
 - c. A five minute temperance segment: The segment could be included as an educational feature, a quiz, brief discussion about newspaper clippings, etc. This could be done for Adult Sabbath school, the time between services on Sabbath and AY Meeting, etc.

METHOD OF TESTING

Memorization of 1 Cor. 9:24-27 and explanation of the meaning of "temperance."

REQUIREMENT 2

Discuss with your leader physical fitness and regular exercise as they relate to healthful living.

CLASS PERIODS: ONE**OBJECTIVE**

To help the Companion understand the meaning and value of regular exercise.

TEACHING METHODS

1. Discussion led by teacher to imagine and record the basic changes in the lifestyle of someone living 100 years ago as compared to today. e.g. changes in transportation; changes in job occupation, i.e. from rural-based existence to urban; growth in automation and technology in the home and on the job; changes in ratio of "free or leisure" time to "work" time; changes in recreational pursuits. Arriving at the conclusion that today we do not meet basic exercise needs in our lifestyle either at home or on the job.
2. Discussion of the principles of physical fitness based upon the booklet "*Fitness and Your Heart*" (National Heart Foundation):
 - a. What activities are best suited to improve cardio-vascular fitness?
 - b. How much time needs to be spent in exercise?
 - c. How hard (i.e. intense) does an individual need to exercise for the exercise to be beneficial?
 - d. Importance of building habit patterns and developing recreational skills early in life.
3. Have the participants compile a collection of advertisements from magazines and the press that tend to promote a sedentary lifestyle.
4. Ask each participant to list his present exercise program and make suggestions where improvements could be made.
5. Invite a doctor or nurse to give a talk on physical fitness. Suggest that the speaker add impact to his talk by conducting a few simple tests e.g. pulse rate before and after exercise; lung capacity; blood pressure.
6. The participant may graph his or her heart rate response over a period of time.

RESOURCES

Fitness and Your Heart- National Heart Foundation, available on request from your local conference temperance department.

The Aerobics Way, Kenneth Cooper - Bantam Paperbacks.

Future Shock, by Alvin Toffler - Pan Paperback.

Film: *Run Dick, Run Jane* - Brigham Young University.

Film: *The Physical Side of Health* - Walt Disney Production

METHOD OF TESTING

Participation in discussion and activities.

REQUIREMENT 3

Learn about the detrimental effects of smoking on health and fitness.

CLASS PERIODS: ONE**OBJECTIVE**

To discover the physical effects that smoking has on the lungs, heart, and general fitness.

TEACHING METHODS

1. View and discuss a film such as "Dying For A Smoke." Ask your local conference temperance department for a list of films available.
2. Smoking machines can be obtained from the local conference temperance department to demonstrate the tar content of cigarettes:
 - The Mechanical Smoker uses a paper filter through which the smoke is drawn. The clean filter can then be compared with a colored chart showing various discolorations according to the tar content of the cigarette.
 - The Humpty Dummy blows the smoke into a small plastic envelope containing a drawing of lungs. The tar condenses and stains the lungs. This can then be passed around the group.
 - Smoking Sam has glass jars filled with cotton wool through which the smoke passes; the tar stains the cotton wool.
3. After the participants have studied about the harmful effects of tobacco, have them write their own pledge of commitment to a lifestyle abstaining from the use of tobacco.

METHOD OF TESTING

Participation in activity and writing and signing of pledge.

REQUIREMENT 4

Complete the Advanced Beginner's Swimming Honor.

CLASS PERIODS: OUT-OF-CLASS TIME**OBJECTIVE**

To develop the art of swimming for personal pleasure, safety, and fitness.

..... **ADVANCED BEGINNER'S SWIMMING HONOR REQUIREMENTS**

Requirements

1. Demonstrate deep-water bobbing.
2. Demonstrate floating positions.
3. Demonstrate rotary breathing in chest-deep water.
4. Dive from the side of the pool from stride and standing positions.
5. Perform elementary backstroke-ten yards.
6. Demonstrate sculling on back for five yards or fifteen seconds.
7. Swim front crawl for 25 yards with rotary breathing.

8. Swim back crawl for 25 yards.
9. Demonstrate breaststroke kick with or without kickboard for ten yards.
10. Demonstrate scissors kick with or without kickboard for ten yards.
11. Demonstrate change of direction at wall.
12. Tread water with any kick for two minutes.
13. Demonstrate rescue breathing.
14. Watch CPR demonstration.

***Note:** Any approved life jacket, vest, or seat cushion may be used.

EXCEPTIONS

The local conference youth director should be consulted if there are any problems in meeting this requirement. A youth who is declared by a physician to be physically unable to swim may substitute an honor not previously earned.

TEACHING METHOD

Having already completed the Beginner's Swimming Honor, the Companions are likely to be a little self-confident and may need extra supervision.

If there is no one sufficiently proficient to teach this honor to your class, then you should refer your group to a recognized swimming school or lifesaving society.

The instructor should:

1. Make sure there is plenty of supervision.
2. Watch for currents and holes at beaches.
3. Be careful of snags, rocks, and holes at rivers.
4. Wherever possible, use swimming pools as the water is clear and its depth regulated.

RESOURCES

Red Cross

METHOD OF TESTING

Demonstration of proficiency

ADVANCED REQUIREMENT 1

HIV/AIDS curriculum

TEACHING METHOD

1. Define and discuss values and traditions.
2. Define and discuss what is meant by ethical choices and ethical behavior.
3. Define and discuss SDA biblically-based foundation of values:
 - Honesty
 - Integrity
 - Fidelity
 - Fairness

- Caring for Others
 - Respect for Others
 - Responsible citizenship
 - Pursuit of Excellence
 - Accountability
4. Focus on ethical values in God's plan as they relate to sexuality - before marriage and in marriage.
 5. Zero in on values based on tradition and cultural norms contrary to biblical standards as they relate to sex before marriage and in marriage.

ADVANCED REQUIREMENT 2

Attend a five day plan, **or** view two films on health, **or** make a poster on smoking **or** drug abuse, **or** help prepare a display on tobacco for a show, etc.

RESOURCE

Contact your local conference temperance department for advice and suggestions on fulfilling this requirement.

ORGANIZATION AND LEADERSHIP DEVELOPMENT

REQUIREMENT 1

Plan and lead a devotional service for your group.

CLASS PERIODS: ONE

TEACHING METHODS

Consider the following potential times for devotionals:

1. Start of each Pathfinder meeting
2. AJY Society Meeting
3. Vespers at church
4. At close of Sabbath while on a hike
5. On campouts-morning, evening.

Some topic suggestions:

1. Requirement 3 from Spiritual Discovery
2. Requirement 1 from Health and Fitness
3. Requirement 3 from Nature Study
4. Requirements from Pathfinder honors, etc.

REQUIREMENT 1

Help your unit or club plan a special activity such as a party, hike, or overnight campout.

CLASS PERIODS: ONE, PLUS EVENT

TEACHING METHODS

Juniors always love to attend parties, and especially so if they have a part in the planning. The leader, therefore, will begin organizing the event with an open discussion with the juniors to set up guidelines and principles and to incorporate as many ideas as possible from the juniors to include them in the various responsibilities. Organization will include at least the following essential points:

- a. Meeting place, date, and time
- b. Party theme and decoration needs
- c. Who will be invited to attend
- c. Games to be played
- d. Food preparation and service

Involvement of Juniors

It is intended that the Companions will have a voice in planning the party and that they will be involved in all aspects of organizational responsibilities and in conducting the activities.

Following are suggested party outlines that will serve as a stimulator of ideas for the Companions in organizing their own party:

FRIENDSHIP - GET ACQUAINTED PARTY (NEW YEAR)

Decorations	Being the New Year, it would be well to decorate the hall with bells, streamers, calendars, hour glasses, scythes, and clocks. These can be made of paper and cardboard and painted with appropriate water color paints.
Welcome	Prayer Be seated in pre-arranged chairs around hall
Games	1. "Find the Name" (Games can be timed with an hour glass) 2. "Dog and Bone"
Story	Short Story (10 minutes)
Group Sing	"Old McDonald Had A Farm"
Game	3. "Action Words"
Treats	Fruit Punch
Benediction	Dismissal

Games

1. **Find The Name:** A sheet of paper, printed, duplicated, or copied with the letters of the alphabet listed on it is given to each person. He tries to fill in after the letters the names of Companions that start with the letter. (ILLUSTRATION: S-Suzy). First, middle, or last names can be used. One who gets the most in time limit wins. When Companion is asked his name, he must tell. It must be designated though whether first, last, or middle name by the one asking. This is a good "get acquainted" game.
2. **Dog and Bone:** Companions, in two teams, line up with ten meters between the lines. Teams face each other and number through, thus there are two participants for each number - one in each line. The bone (a neckerchief) lies on the floor in the center. The leader calls "SIXES" and the two "Sixes" dash out, each trying to grab the bone and get home before the other "six" tags him. Score: One point for getting safely home or for tagging other player carrying the bone.
3. **Action Words:** A set of alphabet cards is the first requirement. These can be purchased or easily made by the leader and should be of cardboard heavy enough to be thrown. The players should be in a straight line or seated closely together in a group. The leader has a subject in mind and announces this. He then quickly flashes a letter, and the first player to name a word in that subject receives the card. For instance, the leader is thinking of birds. He flashes the letter O and the first player to name a bird beginning with O receives the card. The player with the most cards wins. This game has almost limitless possibilities. Some of the suggested subjects might fall under the following headings:
 - **Bible:** Books of the Bible, famous characters, famous places, denominational terms and leaders.
 - **Nature:** Birds, flowers, insects, trees, animals, fish, reptiles, fruit, vegetables.
 - **Geography:** Cities, states, rivers, lakes, mountains, nations. Physiology: Bones of the body, diseases, medicines.
 - **Literary:** Books, poems, authors, poets.
 - **Historical:** Famous politicians, heads of state, events in history, explorers and adventurers.
 - **Art:** Artists, sculptors, paintings, statues.

If the leader wishes, he may make up a story as he goes along, and if his subject is nature, for instance, he may flash a card for the names of trees, animals, and flowers as they occur in the story.

Where there are larger numbers, two groups could run simultaneously.

HARVEST FESTIVAL PARTY

Decorations	Brown, orange, black, and green crepe paper streamers. Large horn-of-plenty filled with all sorts of vegetables, fruits, nuts, and canned goods. Sheaves of wheat, pumpkins, etc. Dress: Dressed like old-timers and early settlers.
Welcome	Include a prayer and be seated. Group Sing.
Games	1. "Find the Birds" 2. "Pointer"
Story	Early Settler Story or Folk Story (10 minutes)
Games	3. "Goal" 4. "Blind Taste"
Potluck Tea	Variety of goodies
Benediction	Dismissal

Games:

- Find the Birds:** Identify the names of ten birds as you read through the following sentences. Names are underlined for teacher's help.
 - Beth rushed down the steps and got into the sleigh.
 - She said, "Here, Rob, in you go."
 - She lifted her little brother into the seat. "I will drive awhile, Ole," she said to the coachman. "Or I, Ole," said little Rob.
 - The mountains in the distance were part ridged with snow, although it was midsummer.
 - As they reached the shore, a boat with a single spar rowed silently out to sea.
 - While returning, the horse became frightened and Ole wrenched the lines from Beth's hands.
 - This saved the sleigh from running into an old poplar, knotty and tough.
 - "If that had been a wobbly spar, rotten and weak, it would have been more dangerous", said Beth.
 - "Ow, let's hurry home", cried Rob.
 - His golden crown of hair was all covered with mud.

Answers: 1. Thrush; 2. Robin; 3. Oriole; 4. Partridge; 5. Sparrow; 6. Wren; 7. Lark; 8. Parrot; 9. Owl; 10. Crow.

- Pointer:** Form a circle and have one player stand in the middle blindfolded. He holds a pointer or baton in his hand. Those in the circle skip slowly around, humming a designated tune, and stop at a specified time. When they stop, the player in the middle points his baton at someone who must immediately begin to sing the tune. He of course tries to disguise his voice, but if the blindfolded player guesses who it is, the two players must exchange places.
- Goal:** Arrange the players in a circle and have them stand with their legs wide apart. Secure a large ball for this game, such as a soccer ball or basketball. One player stands in the center with the ball and tries to score a goal by rolling the ball between the outstretched legs of some player in the circle. Those who are in the circle may only defend the "goal" by using their hands to prevent the ball passing between their legs and must not at any time of the game move their legs. Unless the ball is coming toward a player, he should have his hands on his hips. When the player in the center scores a goal, the player on whom the score is made must take his place in the center and must stay there until he succeeds in scoring.
- Blind Taster:** Blindfold a player and ask him to hold his nose tightly so that he can't smell, then have him taste several items like fruits, sweets, vegetables, etc., and try to identify them.

FRIENDSHIP CHRISTMAS PARTY

Decorations	Christmas tree, holly, wreaths, bells, red ribbons, evergreen boughs, and candles. Dress: Casual for games.
Welcome	Prayer. Be seated in chairs.
Group Sing	Christmas Carols
Games	1. "Candle Relay Race" 2. "Cross Examination"
Story	Christmas Story (10 minutes)
Group Sing	Christmas Carols
Games	3. "Circular Gift Chairs" 4. "Rabbit"
Treats	Christmas treats and punch
Story	Christ's love for us
Benediction	Dismissal

Games:

1. **Candle Relay Race:** Divide in teams - each team with a different colored candle. Light candle and run to point and back. If the candle goes out, the individual starts again. Pass the candle to the next team member on return. The first team finished wins.
2. **Cross Examination:** Have the group form two rows facing each other and with enough space between for the person acting as judge to pass between them. The judge addresses a remark to one of the persons present or asks a question or calls his name. The one spoken to is not to answer, but the one sitting opposite him must reply to the question. The object of the game is to get the one who is not supposed to reply to answer-- and the one who is, not to speak. The judge therefore should be quick in hurrying from one to another with his question. No one must be allowed to remind another of his turn to speak. Those who miss take the place of the judge.
3. **Circular Gift Chairs:** Make a large circle of chairs. Place a gift on each chair. Have girls play game first and have only girls' gifts on chairs. Have juniors each bring a gift. Play music and have them march around. When music stops, they take the gift in front of them.
4. **Rabbit:** Players divide into groups of threes and scatter into groups around the playground. Two of the three form a "home" by facing each other, joining hands. The third one will be the "rabbit" simply standing in this house. In addition there should be two extra players, a homeless rabbit and a hunter. The hunter starts the game by chasing homeless rabbit around, in and out of groups. When the rabbit has grown tired, he may go into one of the homes, and at once the rabbit who was already there must leave and is chased by the hunter. When the hunter catches a rabbit, the two change places--the hunter becoming the rabbit and the rabbit becoming the hunter.

RESOURCES

Additional game and party resources may be found in the *Pathfinder Staff Manual*.

ADVANCED REQUIREMENT 1

Participate in a special club event such as an investiture, open house, induction, or Pathfinder Sabbath, and then evaluate the event to determine how it can be improved.

CLASS PERIODS: PART OF ONE FOR EVALUATION**TEACHING METHODS**

Pathfinders should develop the art of evaluating performance and planning procedures in a constant search for improvement. Values may be established, effectiveness in outreach modified as Pathfinders recognize the significance of all they do and say.

NATURE STUDY

The purpose of this section is to introduce the Companion to the thrill of discovering God's "book of nature" and to develop a sense of accomplishment by completing Pathfinder honors.

Seven class periods have been allocated to teach this section, with the understanding that some of the honors may require out-of-class work. One class has been allocated for the advanced section.

REQUIREMENT 1

Participate in nature games **or** in a one-hour nature walk.

CLASS PERIODS: OUT OF CLASS TIME

OBJECTIVE

To teach the Companions to familiarize themselves with God's "second book."

TEACHING METHODS

1. Refer to the staff manual for nature games.
2. Use the hour nature walk to do the practical work involved in Requirement 1 or some other nature honor.

RESOURCES

Administrative Staff Manual.

METHOD OF TESTING

Participation in chosen activity.

REQUIREMENT 2

Complete **one** of the following honors: Amphibians, Birds, Domestic Animals, Poultry, Reptiles, Shells, Shrubs, or Trees.

CLASS PERIODS: FOUR

OBJECTIVE

To continue to develop in the Companions a desire to study and to appreciate the handiwork of God in His creation.

TEACHING METHOD

The requirements are listed for your convenience. Teacher's notes have been prepared and are available for your use from the youth department of your local conference. Do not just read the notes. Make the classes more interesting by using samples, pictures, or going on field trips.

Inquiries may reveal that you have someone in your church or in your community who is a specialist in one or several of these topics.

Have the Companions do research and encourage them to make up personal scrapbooks on the honor. These will be good for future reference—they may become teachers later on.

Slides, films, guest speakers, visits to farms and zoos all add to the enthusiasm of the Companion to participate.

AMPHIBIANS

Skill Level 1

Requirements

1. What are the characteristics of amphibians?
 2. Name the two main orders of amphibians and tell how to distinguish between them.
 3. Distinguish between toads and frogs.
 4. How do amphibians protect themselves?
 5. Make a list of amphibians that should be found in your locality. Identify five and tell where you found them.
- OR**
- Collect pictures or sketch five different amphibians that you can identify and tell where they are found.
6. Describe the life history of some amphibians.
 7. Explain the economic value of amphibians.
 8. Where do toads spend the winter or the dry season?
 9. Identify two species of frogs by their sound or imitate the sounds of two different species of frogs.
 10. How do frogs and toads sing? What makes the noise so loud?
 11. Do one of the following:
 - a. Observe an amphibian to find out:
 - where and when it sleeps.
 - when it leaves its home for food.
 - how fast it can travel.
 - how far it can jump, and as many other interesting things as you can find out about it; Or hatch frog eggs in your own aquarium and watch them grow to tadpoles, Or write an essay covering the details requested in the first section of this question.
 - b. Hatch some amphibian eggs and watch them through their growth cycle and write an essay covering the details.

BIRDS

Skill Level 1

Requirements

1. Give two characteristics that set birds apart from all other creatures.
2. Name three flightless birds, tell what their diet consists of, and name the country or continent in which each one lives.
3. Give the day of the week when birds were created. Find in the Bible the names of five birds and be able to name them from memory.
4. Write or give orally three ways in which God's love and purpose is shown in the creation of birds.
5. Make a list of thirty species of wild birds, including birds from at least five different orders, that you personally have observed and positively identified by sight out of doors.
6. Make a list of five species of wild birds that you personally have positively identified by sound out of doors.
7. Do one of the following:
 - a. Set up a feeding station and report on the bird visitors observed for a period of seven days.

- b. Find a bird's nest, identify the species of the bird that built it, describe the nest in detail, observe the nest for five days, and report what happened at the nest on each of the days.
- c. In the Western Hemisphere: Maintain a hummingbird feeder for two months.
 - What does man-made nectar consist of?
 - Why shouldn't you use food coloring or honey?
 - When should the feeder fluid be changed?
 - How should the feeder be cared for?
- d. In other areas of the world: Select at least three different habitats in your area and make comparative bird lists of them indicating the differences in birds expected and found.

LIVESTOCK

Skill Level 2

Requirements

1. Distinguish between the draft horse and the light horse.
2. Identify from pictures or personal observation and record the height, weight, color, and disposition of at least three of the following horses: Percheron, Belgian, Clydesdale, Arabian, Shetland.
3. List four physical characteristics of the mule.
4. Identify a burro from a picture or personal observation. Give its size, color, and usefulness.
5. Identify from pictures or live animals four kinds of milk cattle and four kinds of beef cattle.
6. Know the milk producing qualities of the Jersey, Guernsey, and Holstein breeds.
7. Differentiate between the Angora and milch goats. Give the distinguishing color of at least three breeds of goats such as Saanen, Toggenburg, Nubian, and British Alpine.
8. Identify from pictures or live sheep and note wool and meat production, size, markings, and general appearance of three breeds of sheep such as Merino, Rambouillet, Shropshire, Hampshire, and Lincoln.

POULTRY

Skill Level 2

Requirements

1. Identify by description or from pictures at least five breeds of chickens such as:
 - a. Plymouth Rock (any color)
 - b. Wyandotte (any color)
 - c. Rhode Island Red
 - d. Orpington (any color)
 - e. Leghorn (any color)
2. State orally or write a short paragraph regarding the egg-laying or meat-producing qualities of each breed.
3. Identify by description a Peking duck.
4. Identify by description or from pictures three breeds of large domestic fowl such as the following turkeys:
 - a. Mammoth Bronze turkey
 - b. White Holland turkey
 - c. Bourbon Red turkey.
5. Identify by description or from pictures two breeds of domestic geese such as:
 - a. Toulouse goose
 - b. Emden

- c. Chinese Geese
 - d. Sebastopol Geese
 - e. Cape Barren Goose
6. Visit a poultry farm or agricultural fair and write a brief report on the various types of poultry observed.

REPTILES

Skill Level 1

Requirements

1. What characteristics must an animal have to be classed as a reptile?
2. Name fifteen reptiles found in your locality. Tell where they live, their food habits, and their economic importance.
3. Name five poisonous reptiles in your area describing each as to location of fangs and geographical distribution.
4. Tell what to do if you are bitten by a poisonous snake.
5. Tell what to do if you are bitten by a non-poisonous snake.
6. Do one of the following:
 - a. Tell the life history of one representative of each: lizard, snake, turtle.
Compare lizards, snakes, turtles, and crocodiles as to life history, variation in eyes and ears, teeth, heart, lungs, limbs, tails, and scales (shells).
 - b. Keep a small reptile in a terrarium and maintain a record of its care for at least three months.
7. Be able to tell two Bible stories in which a reptile played an important part.

SHELLS

Skill Level 2

Requirements

1. What is the meaning of the term "mollusk"?
2. Identify the following from shells or drawings:
 - a. Mantle
 - b. Foot
 - c. Teeth
 - d. Ribs
 - e. Valve
 - f. Dorsal border
 - g. Apex
 - h. Operculum
 - i. Canal
3. Are all shells found on beaches? Where are they found? What areas of the world offer the largest variety of shells?
4. Describe the movement of shells from place to place.
5. How do shell animals protect themselves?
6. How are shells made and from what materials are they made?
7. List and explain five uses made of shells by man.
8. Explain the terms univalve and bivalve as applied to shells.
9. Name in common terms five different classes of shells, and have in your collection a shell for each class.
10. Make a collection of twenty different shells and tell where each is found, when it came into your possession, and classify it.
11. What is the source of pearls? What striking lesson does the pearl teach us? (Read Christ's Object Lessons, p. 115 - 118.)

12. Which of the Bible texts given below tell us that:

- a. water creatures were created on the fifth day.
- b. the number of water creatures is innumerable.
- c. water creatures perish out of water.
- d. Job considered coral of great value.
- e. Solomon was acquainted with marine life.
- f. Jesus twice used a shell product to teach a spiritual lesson.
- g. a business woman was engaged in selling the famous purple dyes secured from the shellfish Mediterranean Murex.
- h. Paul condemns the wearing of pearls.
- i. shell creatures are unfit for food.
- j. the twelve gates of the Holy City are twelve pearls.

The following texts are of help (they are not in order!) : Lev. 11:9, 10; Acts 16:14; Isa. 50:2; Rev. 21:21; I Tim. 2:9; Gen. 1:20, 21; I Kings 4:33; Ps. 104:25; Matt. 7:6; 13:45, 46; Job 28:18.

SHRUBS

Skill Level 1

Requirements

1. Note three characteristics of shrubs that distinguish them from trees and herbs. Why is a grape vine sometimes regarded as a shrub?
2. Name three important wild or cultivated food shrubs of your locality. Name a shrub that produces edible nuts.
3. Name two cultivated shrubs and two wild shrubs of your locality that produce showy flowers.
4. Do most shrubs blossom in the spring, summer, or autumn? Name one shrub whose flowers open before the leaves appear.
5. What parasitic shrub frequently used for indoor decoration grows on the high branches of different kinds of trees?
6. Give an example of a shrub whose leaves in autumn turn from green to brilliant shades of yellow, orange, or red.
7. Observe some shrub that is in bloom and list as many kinds of insects as you can (at least three) that come to its blossoms for pollen or nectar.
8. From what shrubs do birds prefer to eat the fruit or seeds? Name a shrub whose flowers attract birds.
9. In what shrubs do birds prefer to build their nests?
10. Collect, preserve, and correctly identify the flowers, leaves, seeds, seed pods, or twigs with buds of ten wild shrubs.

TREES

Skill Level 1

Requirements

1. Describe the ways in which trees and shrubs differ.
2. Collect and identify typical leaves from fifteen different species of trees. Spread neatly, press dry, mount, and label in a suitable notebook or on uniform-size sheets of paper.
3. Know your specimens from memory, and upon request be able to identify similar specimens in the field.
4. Name two examples each of trees that have been named for:
 - a. what they are used.
 - b. the surroundings or environment in which they grow.
 - c. some distinctive feature.
 - d. the geographic region in which they live.
 - e. persons who first found and described them.

5. Give the common name and tell the difference between the two great classes of trees.
6. Describe the importance of forest conservation in your area.
7. Name several examples of the kinds of wood used in each of the following:
 - a. Flooring for houses
 - b. Common plywood
 - c. Furniture
 - d. Ax handles
 - e. Fence posts
 - f. Railroad ties
 - g. Support beams for construction work
 - h. Bows and arrows
 - i. Ideal for use as kindling
 - j. Burn slowly and leave a bed of hot coals
8. Name two examples each of trees that:
 - a. grow best in wet or marsh places
 - b. grow best at high levels in mountains

RESOURCES

Additional resource books may be obtained from established book stores or from your local library.

METHOD OF TESTING

Demonstration of proficiency.

REQUIREMENT 3

Review the story of creation and keep a seven day outdoor log of your personal observations from nature in which each day focuses on those that were created on that day.

CLASS PERIODS: ONE, AND OUTSIDE PROGRAM TIME

TEACHING METHODS

Application - Discussion

"By the word of the Lord were the heavens made; and all the host of them by the breath of his mouth" (Ps. 33:6).

"In the beginning was the Word, and the Word was with God, and the Word was God. The same was in the beginning with God. All things were made by him; and without him was not anything made that was made. And the Word was made flesh, and dwelt among us, (and we beheld His glory, the glory as of the only begotten of the Father,) full of grace and truth" (John 1:1-3 & 14).

The purpose of this requirement is to instill in youth the solid conviction that Jesus was and is the Creator of all things and that the Genesis story of creation is central to understanding the plan of salvation. Inextricably tied to the creation story is the doctrine of the seventh-day Sabbath. The youth who fulfill this requirement should have an understanding of the relationship between creation and the Sabbath in terms of the plan of salvation.

The story of how things began in Eden is probably the most magnificent and wondrous story ever told, except for the story of Jesus' coming to save that which He had created. Young people should be led to see the adventure and the wonder of the

creation story. Help them to hear and to see what might have happened. Then make sure that they understand that we cannot even imagine the perfection and wonder of it all.

Talk to them about what it might have been like each day. What was it like before day one? Talk about darkness—complete darkness without any source of light that we know about; it was like being in a cave when all of the lights are turned off—that’s dark! Where did the light come from on the first day of creation?

Tell them about the arrival of Jesus, the Light of the World, on the first day. Where Jesus is, there cannot be darkness. Some of the young people aspiring to be Companions may still be afraid of the dark. Tell them about Jesus and how He takes care of us when we are in the dark.

Why did Jesus create the world? Was there a logical order to the way Jesus made the world? What were the animals like then, the birds, the insects, the flowers, the trees, the clouds-everything?

How did Jesus make the world and all that is in it? How does His creative power relate to you and me? Are we beyond the power of the Creator of the whole universe? Or course we’re not, but some young people believe that God is too busy to be concerned about them or that they aren’t good enough to merit His careful attention. So teach them about the detail with which Jesus created everything on earth. With full realization that sin was going to come in and mess things up, He still took careful pains to make everything on earth perfect in every detail. Think of it!

SUGGESTIONS

1. If possible, get the aspiring Companion to relate the story of creation as a testimony of the creative power of Jesus, not only in the world, but also in his/her own life. Make the telling of this experience something special; it could be given as a testimony in church or in a school assembly. But perhaps the most meaningful way to tell the story would be to share it around a campfire under the starry heavens or on the seashore as the waves pound the beach with the power given to them by the Creator.
2. To make the creation week a bit more meaningful, the future Companion is asked to keep a daily log for one week, recording for each day those natural phenomena that he/she sees, hears, or otherwise experiences that illustrate each of the days of creation. Try to have the youth begin the log on Sunday, the first day of the week, so the culmination of the experience can be on Sabbath, the seventh day. Also, it would be a wonderful supplement to the requirement if several experiences could be planned through the week that would help the young person learn about the significance of that day in the creation week. For example:

First Day: Make a note of all of the sources of light that you can find. How many of them are natural, occurring without the help of man? How many of them are present on the first day of creation week? If possible, take a field trip to a cave and have all of the lights turned off so the youth can experience the intensity of the darkness in the total absence of light.

Second Day: Keep a weather chart for the day, noting the temperature, wind direction, and wind speed (if available), and any precipitation. If possible, visit the local weather station or water treatment plant. Make a note of the various forms of pollution that are observed in the water and/or air that day.

Third Day: Make a note of the time of year and of what state the various plants are in (e.g. spring buds, summer fruit, fall colors, winter dormancy). The youth might want to collect some leaves from several trees, identify them, and press them for their notebooks; or they might want to do the same with some flowers found that day. If possible, visit a nursery or a botanical garden and note the many varieties of plants. Talk to a gardener, nurseryman, or farmer to get some idea of the various requirements that must exist in order for plants to grow healthy. If you live where there is open water, notice that there are also water plants that grow where there is no dry land.

Fourth Day: Note the presence of the star that gives us light by day, and note the status of the moon on that date (i.e. new moon, first quarter, and so on).

Have the youth take a look at the stars, if visible, and see if they can count them. It would be wonderful if you could take the future Companions to a planetarium to get a more adequate perspective of just what the sun, moon, and stars are all about. Note the effects of the sun and/or the moon (e.g. the tides, suntan, evaporation of water, plant growth, and others).

Fifth Day: Make a list of the birds seen and see how many the youth can identify; also, see how many they can identify by sound. You might want to set up a bird feeder, visit someone else’s feeder, or visit an aviary. Record what is seen

there. Beyond just identifying the birds have the youth make some notes about what the birds are doing and give some possible reasons for the birds' behavior. Also, on this day see if you can observe any fish, such as in a public or private aquarium, stream, or even a local pet shop. Record the observations.

Sixth Day: This is a special day for observing and recording the creation week. Not only were all of the animals and creeping things created on this day, but also Adam and Eve were as well. You might want to have the youth divide their observations for this day into two parts: (1) animals and creeping things, and (2) interesting things that you see people doing. Try to determine whether the things that you see these groups doing are things that they (both animals and people) would have done on the sixth day of creation week.

Seventh Day: Since this was the day set aside for His people to remember Him and how much He loves them, try to observe natural wonders that illustrate the care and keeping of Jesus for His creatures. It may be a mother cat washing her kittens, a bird building a nest, a rainbow, the shade of a tree; it can be an endless number of things. Be sure that the observations made on this day are special; try to draw from the natural observations some personal message of love from Jesus to all of us.

ADVANCED REQUIREMENT 1

Identify and describe twelve birds and twelve trees.

CLASS PERIODS: TWO

OBJECTIVE

The purpose of this requirement is to introduce the Companion to an elementary step in nature appreciation, which is the ability to identify specific flora and fauna.

TEACHING METHODS

Field observation is the best method for teaching this requirement. Pictures are only second best. A visit to a museum will also make a worth-while outing. You may consider this is an excellent time to earn Pathfinder honors in birds and trees.

The following are supportive teaching methods:

1. Play a game of "identify." See who can accurately identify the greatest number of birds in a given time. You could do this by book or loose pictures before or after your field outing.
2. Slides for instruction purposes are also usable in your game.
3. An aviary, if available, can be visited to great advantage.
4. Park rangers in forest service areas would be happy to talk to your youth and help them to identify the trees.
5. Extend their knowledge and interest by identifying bark of different trees and nests and eggs of different birds. (But don't collect any!)
6. There are also interesting details on bird migration that again show God's great love and concern.

METHOD OF TESTING

Demonstration of ability to identify twelve birds and twelve trees.

Note: If one of these two honors has been selected and completed, that portion of this requirement has been fulfilled automatically.

OUTDOOR LIFE

The purpose of this section is for the Companions to continue developing their outdoor living and safety skills. Six classes have been allocated for the basic course and three for the advanced segment. Out-of-class time will be needed for practical work.

REQUIREMENT 1

Find the eight general directions without the aid of a compass.

CLASS PERIODS: ONE

OBJECTIVE

To teach the junior how to use the natural laws for his own, and perhaps others, advantage and protection.

TEACHING METHOD

A variety of teaching ideas are listed. You may give your class a working knowledge of them all, but encourage them to specialize in at least one.

It may be a good idea to invite someone from a hiking club to give the class a talk; show some films or encourage the juniors to read such books as "Stay Alive." Be sure to take the participants out on at least one practical exercise.

DIRECTION FINDING WITHOUT THE AID OF A COMPASS

All of us are likely, at some time or another, to get lost. With the aid of a compass, of course, this need never happen because the needle of the compass will never fail to point north. However, even without the aid of a compass, it is still possible to find one's directions. For hundreds of years before the discovery of the compass, man has been able to navigate by means of the sun and stars. Pathfinders can learn to do just that. There are several methods—some are useful in the daytime and others at night.

1. Direction Finding by Day

A. By the Time

- at 6 am, the sun is due east at 9 am, it is north east
- at 12 noon, it is due north at 3 pm, it is north west
- at 6 pm, it is due west

In the wintertime, the sun rises later than 6 am and sets earlier than 6 pm in far northern or far southern latitudes, but it is still due east at 6 am and due west at 6 pm even though it cannot be seen.

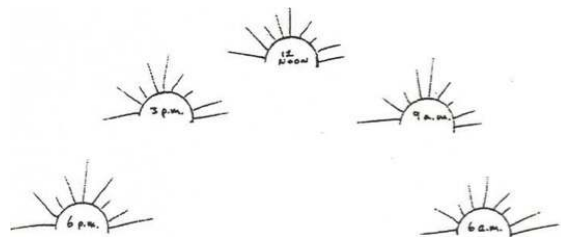

B. By Shadows

This method is useful only when you spend many hours through the middle of the day in one spot on a cloudless day. Poke a stick in the ground and make a line on the ground along the shadow that it casts. At intervals throughout the day, repeat this. You will notice that the lines that you have drawn on the ground will gradually diminish in length, and then will increase again.

The shortest line will be the one that was cast when the sun was at its highest point, therefore this line will be the one that is most nearly pointing north and south.

If you have a piece of string to aid you to draw a circle around the stick, you can get an even more accurate result. Tie one end of a piece of string to the stick in the ground and attach another stick to the free end. Use this to draw the circle, first noticing where the shadow ends. This shadow will be the radius of the circle. Owing to the movement of the sun, the shadow will leave the circle, becoming smaller, and will return to the circle later in the day.

Mark the point at which the shadow meets the circle again, then draw a line from the center of the circle half-way between the two points on the circle. This will point due north in the Northern Hemisphere or due south if you are in the Southern Hemisphere.

C. With a Watch

Should you have a watch, it is a simple matter to find north and south. Point the figure "12" towards the sun. Place a pencil or stick across the face of the watch, half-way between the 12 and the hour hand. This will give you north and south. In the morning, the south will be on the left-hand. In the afternoon, it will be on the right.

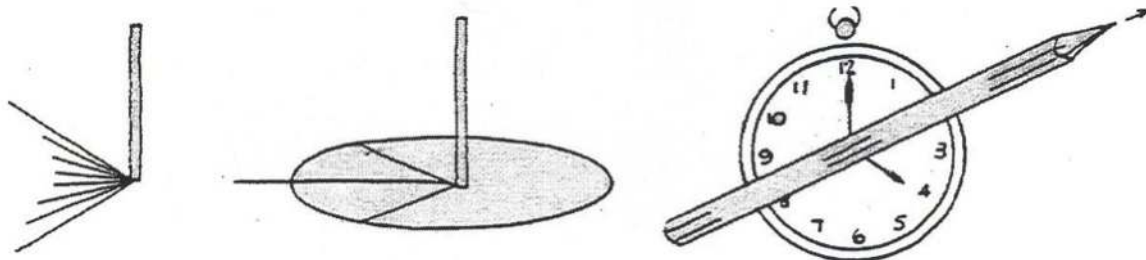

2. Direction Finding by Night

a. In the Southern Hemisphere by the Southern Cross or the Pointers:

- If you carry your eye along in the same direction as the long axis of the Southern Cross for a distance of about four times its length, this point will be about due south.
- Or, if you imagine a line extending from between the Pointers to a point where it cuts this line, you will get south.
- If Achernar is visible, a point half-way between it and the Southern Cross will be approximately the position of the South Celestial Pole.

b. In the Northern Hemisphere by the Big Dipper:

Ursa Major, also known as the Big Dipper, is one of the most important Northern Hemisphere constellations. Pathfinders should be able to readily identify it on any clear night any time of the year. It appears like a large soup ladle that is upside down.

The two stars at the end of the bowl portion point to a star near the horizon known as Polaris-the North Polar Star.

Polaris is actually part of the Ursa Minor constellation, although quite often the other stars of this constellation are not very visible

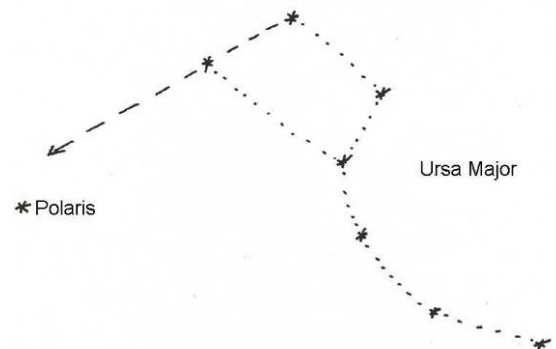

c. By the Moon:

When the moon is full, it is quite easy to find north with a watch following the method using the sun.

Regarding the times when the moon is in its other phases, it is possible to find various points of the compass at certain times only.

The following "fixed standards" are helpful:

• If you are in the Northern Hemisphere:

At 6 pm (Full Moon) and 12 midnight (3rd Quarter) the moon is WEST

At 12 midnight (Full Moon), 6 pm (1st Quarter), and 6 am (3rd Quarter), the moon is SOUTH.

At 6 am (Full Moon and 12 midnight, 1st Quarter), the moon is EAST.

- The directions are opposite for the Southern Hemisphere.

METHOD OF TESTING

Demonstration of ability to find general directions.

REQUIREMENT 2

Participate in a two-night campout. Know at least six points relative to the selection of a campsite.

CLASS PERIODS: ONE PLUS OUT OF CLASS TIME

OBJECTIVE

To teach self-reliance and team work in the out-of-doors, thus helping the participants to gain a sense of responsibility.

EXPLANATION

God comes very close to a Pathfinder while he sits round a campfire or lies beneath a star-studded sky, so campouts are a great time for spiritual growth. This is a class, not a club activity.

- Plan your spiritual activities before you go.
- Plan for your campout to be more than a recreational outing.
- Be familiar with the area.
- Prepare the site as much as possible the week before.

TEACHING METHOD

The class under your guidance should be responsible for planning the camp program and also the menus. You pre-select two or three sites, then allow the class to choose the best location. The group should set up the camp and prepare and cook the meals.

Suggested Program

FRIDAY	Arrive on site, set up Campfire and stories Worship
SABBATH	Rise and personal devotions Worship and Prayer Bands Breakfast and duties Sabbath school Walk (short) Church service Lunch and duties Quiet time (Involve Nature Honor requirements) Get-together period

Walk
 Supper
 Closing Sabbath Campfire and games
 Worship

SUNDAY

Rise and personal devotions
 Worship and Prayer Bands
 Breakfast and duties
 Activities: could attempt requirements from Companion class
 Lunch and duties
 Activities: games with plenty of exercise
 Short worship
 Pack up and return home

Rules for Choosing a Campsite

1. Choose well-drained, level ground.
2. Choose a dry area. Always check the ground carefully, for if it is the least bit damp, the warmth of a body in a sleeping bag will bring the moisture up from the ground and through the bag. Of course, a ground sheet should always be used under a sleeping bag, even if the ground is dry, for there is always a certain amount of moisture in the soil.
3. Stay away from mosquito-infested swamps if at all possible.
4. Never camp under an overhanging ledge or cliff. There is danger of landslides or falling rocks. You may build your campfire near the face of the cliff and take advantage of the reflected heat.
5. In setting up a campsite in a wooded area, be sure the tents are not placed under trees with large dead branches that might break off in the wind.
6. Pick a warm area. Remember that water and cold air both run downhill, and that warm air runs uphill. Because of this law of cold air drainage, where would be the best place to choose a campsite--a hilltop, a hillside, or a basin? A hilltop would be warmer and drier, and it would also have strong breezes to keep away mosquitoes. A hillside would be a little colder, but not too bad, and if very strong winds were blowing this might be the best spot. A basin is never a good idea, for here the dampness of fog will lie, and the cold frost crystals will form. Also, in a heavy rain such a campsite would be flooded.
7. Hard, rocky, dusty terrain makes a poor campsite.
8. Pitch your tent toward the southeast so that the morning sun will help keep it dry.
9. If there is a prevailing wind, pitch the tent with the door away from the wind.
10. A plentiful dry wood supply is important. (Don't cut green wood.)
11. Pick a camping area where plenty of safe drinking water is available.

RESOURCES

Pathfinder Staff Manual, Pathfinder Field Guide.

METHOD OF TESTING

A log book should be signed by the counselor who attends the campout. Companion should participate in the planning of and attend the campout.

REQUIREMENT 3

Learn or review the Friend knots. Tie and know the practical use of the following knots: sheet bend, sheepshank, fisherman's knot, timber hitch, taut line hitch. Learn three basic lashings.

CLASS PERIODS: TWO**OBJECTIVE**

To help the Companion become more skillful in the use of ropes and in tying basic knots and to understand their uses.

TEACHING METHOD

The most efficient method of teaching knot tying and lashings is to:

1. a. Demonstrate the procedure.
b. Have the class follow the instructor, using their own rope.
c. Practice procedure until proficient.
2. Use ropes of different colors as it makes the knots a lot easier to follow.
3. If the participant started the knot board in his Friend class, then he will now be able to add to that board. If he has not already started a board, get him to start one.
4. Have a field day where they can naturally use the knots for practical reasons, e.g. pitching tent-taut line hitch; bringing firewood-timber hitch; throwing light rope across river, followed by heavy rope-sheet bend; and various articles of camp furniture using the basic lashings.
5. This part of their work also lends itself to use in games and challenges the Companion to proficiency.
6. Knots must be used again and again if they are to be remembered.

The Sheet Bend - This knot is used in bending the sheet to the clew of a sail. It is used also when tying two ropes of different thickness together. For example, if a rope needs to be thrown some distance, a string is first tied to a weight of some kind and thrown. Then use this knot to tie the string to the rope. This knot is also valuable in stretching a sheet for a projector screen or in any other case where a cloth must be tied by the corners with a rope or a string. Make a loop with rope, pass the end of the other rope up through and around the whole loop, then bend it under its standing part.



The Sheepshank - This knot is valuable for taking up a slack when both ends of the rope are tied, or for strengthening a weakened rope. Gather up the amount to be shortened, then make a half hitch around each of the bends.

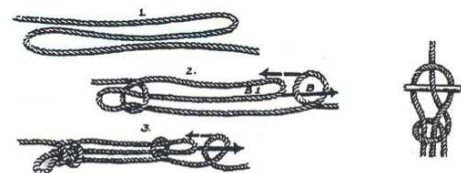

Fisherman's Knot - Useful in tying together anything smooth and stiff such as nylon fishing wire. It does not slip and is easily untied. Lay the two ropes parallel, then with the end of each tie an overhand knot about the other. Pull the two standing parts.

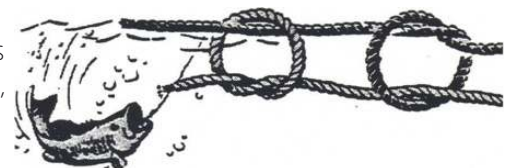

Timber Hitch - Used in hauling timber and for commencing the diagonal lashing. Pass the end of the rope around the timber. Bring it up and around the standing part, then twist it back about itself two or more times. The weight of the timber will hold it securely.

When the knot is used for pulling a log along the ground, at least an extra half hitch should be tied along the log in the direction of travel.



Taut Line Hitch - Used in tying tent rope to pegs. Pass rope around peg. Tie half hitch then tie second half hitch further up rope. Pass the round standing part once again locking rope into half hitch. A round turn on the peg may be added if desired.

Remember to review these knots continuously or they will be forgotten.

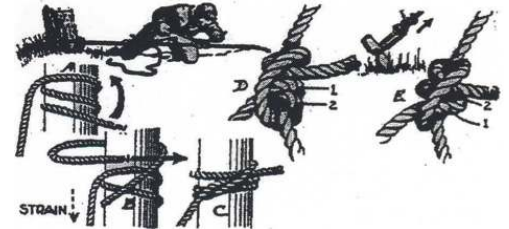

LASHINGS

Square Lashing - This is used whenever spars cross at an angle, touching each other where they cross. It is started with a clove hitch around the upright spar immediately under the spot where the cross piece is to be.

Twist the end of the rope into the standing part, then "wrap" the rope around the cross piece and upright binding them together. In wrapping, rope goes outside the previous turn around the cross piece and inside the previous turn around the upright. After three or four right wrapping turns, make two "frapping" turns between the timbers. Strain them tightly. Finish with clove hitch around end of cross piece. Remember: "Start with clove, wrap three times, frap two times, end with clove."

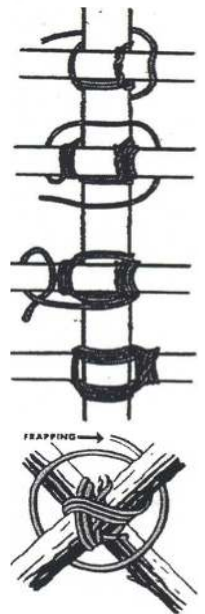

Diagonal Lashing - This is used to "spring" two spars together, that is, to lash together two spars that tend to spring apart and that do not touch where they cross. The lashing is started with a timber hitch around both spars. The timber hitch is tightened so as to bring the two spars together. Three or four turns of the lashing are then taken around one fork and three or four turns around the other fork. Two frapping (tightening) turns are taken about the lashing at the point where the spars cross and the lashing is finished off with a clove hitch around the most convenient spar.



Round or Shear Lashing - This lashing is used for binding together parallel spars and for forming "shear legs" that support bridges and the like. Place the two timbers next to each other. Tie clove hitch around one of them at appropriate place from the top. Bind the two timbers together by laying seven or eight turns of the rope around them, one turn beside the other. Make two frapping turns around the lashing turns between the timbers. Fasten rope with a clove- hitch around the second timber. Open out the timbers.

Note: Two shear lashings without frappings are used to lash two timbers into one long one.

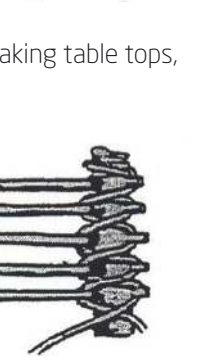

Continuous Lashing - Continuous lashing holds small sticks at right angles to long sticks and is useful in making table tops, seats, etc. Follow these steps in laying a table top.

- a. Cut sticks to desired size and trim ends. Next notch the frame and place the cross pieces in correct position.
- b. Make clove hitch on the frame, in middle of the rope, with knot underneath and ends out to sides. There should be equal lengths of rope on either side of the long stick. The hitch should be

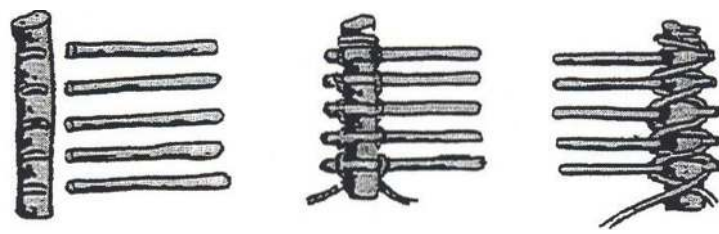

- placed so that the ends of the rope pull the knot tight as they come up from under the long stick.
- With one end in each hand, pull rope over one crosspiece and down under frame.
 - Cross rope, making an "X." Pull rope tight.
 - Bring up and over second crosspiece. Repeat this procedure until all the crosspieces are lashed.
 - End with two half hitches or clove hitches and tuck ends of rope under last small stick.

Camp Furniture - With skills you have just learned in lashing, try making the following camp furniture. If materials are scarce, these models may be built in miniature.

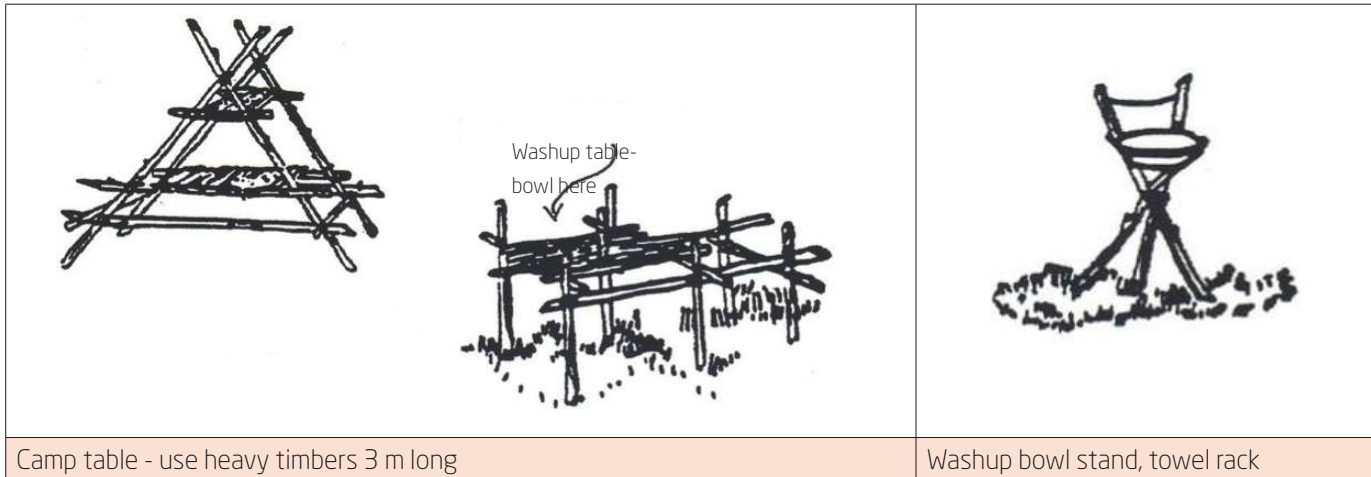

RESOURCE

Scout Handbook, Girl Guide Knot Book, Pathfinder Video: Just Knots

METHOD OF TESTING

Demonstration of proficiency and understanding of the requirements.

REQUIREMENT 4

Pass a test in Companion First Aid.

OBJECTIVE

To teach the Companion basic knowledge and skills in specific areas of first aid.

EXPLANATION

The material for teaching the classes is taken from the *St. Johns Ambulance* or *Red Cross First Aid Manual*. The use of professionals to teach the class is not mandatory but preferred. Do not hesitate to call for help from the community organizations who deal in health and first aid.

TEACHING METHODS

Communicating the principles of first aid is best achieved through:

- Lecture

2. Observation
3. Demonstration
4. Participation

The instructor may also use resources provided by various agencies, quizzes, mock emergencies, and public health department films.

FIRST AID

First aid is the emergency first care given to the sick or injured. The aims of first aid are:

1. Preserve Life
2. Promote Recovery
3. Prevent the injury or illness from becoming worse

THE RULES OF FIRST AID (Remember: "D A N G E R")

- D** Danger Urgently assess the situation and beware of dangers to self, onlookers, and victim.
- A** A.B.C.D. of life-sustaining first aid. Act quickly and confidently to check:
Airway - clear and tilt head back if necessary
Breathing - restore if necessary
Circulation - check pulse, control hemorrhage
Degree of Consciousness - note cause, give treatment
- N** Never leave an unconscious person - place in the coma position and check pulse and breathing regularly.
- G** Get medical assistance when necessary.
- E** Examine the patient for further injuries and treat according to severity.
- R** Reassure the victim, handle him gently, and make arrangements to send patient to hospital, home, etc.

THE FIRST AIDER MUST BE ABLE TO ASSESS:

1. **History** The story behind the accident or illness
2. **Signs** Difference from normal that can be detected - pallor, pulse, etc.
3. **Symptoms** Sensations described by the patient - thirst, pain, nausea.
4. **Diagnosis** Making a decision as cause of patient's trauma.
5. **Treatment** Decide on priorities and act quickly.

THE FIRST AIDER MUST KNOW HOW TO:

1. Take the **pulse** in the radial and carotid arteries.
2. Measure the **respiration** rate.
3. Take the **temperature** .

	PULSE	RESPIRATION	TEMPERATURE
Adults	60-80/min	12-15/minute	98.6°F 36.9°C
Children	100/minute	15-20/minute	98.6°F 36.9°C
Infants	120/minute	20-25/minute	98.6°F 36.9°C

FIRST AID KIT

Avoid elaborate equipment and treatment. Remember, this is “first” aid. Add to this basic list as local conditions indicate.

- 1 pair scissors. Surgical type with one round end.
- 1 pair tweezers. For removing splinters and handling non-stick dressings.
- Band-Aids, safety pins, cotton wool.
- General Antiseptic. Do not use undiluted. 1 teaspoon to 300 mls of water.
- 1 ankle wrap roll 2.5 cm
- Bandages - four triangular bandages (sufficient to cover most emergencies) 2 x N25 mm bandage; 2 x 50 mm bandages; 2 x 75 mm bandages; 2 x 75 mm or 100mm crepe bandages.
- Eye wash. Especially useful for chemicals, smoke, etc.
- Non-stick dressing. Individual packs. Teflon or Tule Gras type.
- Syrup of Ipecacuanha, 100 mls.
- Methylated Spirits.
- 1 packet sterile gauze squares 5 cm x 5 cm.
- Calamine lotion.

TREATMENT FOR SHOCK (Circulatory Collapse)

This term refers to a condition met with in all medical emergencies. It is a state of collapse with a reduction of blood volume circulating to the brain and heart.

Shock is caused by loss of body fluid from bleeding, burns, vomiting or diarrhea, heart attack and poisoning, nervous reaction, and infection.

It is recognized by cold/clammy skin, rapid feeble pulse, rapid shallow breathing, and unconsciousness. The patient often feels faint or giddy, nauseated, and maybe thirsty.

It is best handled by treating the cause as well as:

R Rest Lie the patient down, legs elevated.

A Air Ensure adequate airway. Loosen clothing around the neck, chest and waist.

W Warmth Do not over-heat the body.

WOUNDS, BRUISES

A wound is a break in the skin allowing entry of germs or damage to deeper tissues.

Cuts of any kind are best treated by:

- Cleaning the surrounding area and the application of a mild antiseptic.
- Covering the wound with a suitable sterile dressing if available.
- If there are embedded objects, do not remove. Apply a ring pad or build up dressing to the area.
- Use gauze dressings direct on a wound, never cotton or wool.
- If stitches (sutures) appear necessary, they should be done as soon as possible. Medical advice regarding tetanus injections should be sought.

Bruises

A bruise is a minor hemorrhage into the tissues. It can be recognized by pain, swelling, discoloration, and tenderness. The best treatment is elevation, application of an evaporating dressing and the application of a firm bandage. To reduce swelling, evaporating dressing should be applied for twenty minutes. Ice packs, gel packs, and water may also be used if correctly applied.

Bleeding

Bleeding (hemorrhage) is the loss of blood from the circulation causing reduced blood pressure (weak pulse) and reduced supply of oxygen.

Blood can be lost internally or externally.

External bleeding can be from arteries (usually bright red and spurts out), veins (usually darker red and pours out), and capillaries (as in gravel rash, oozes out).

Treatment: Act quickly as blood loss aggravates shock. Stop the bleeding using direct pressure on the wound where appropriate. Bandage using pad, ring pad, or build up dressing, and elevate the affected part. If bleeding persists after the application of a pad and bandage, add another pad and bandage firmly. Together with rest and elevation, this usually suffices. By resting the patient, we help to reduce blood pressure. Do not disturb clots.

Internal bleeding has all the usual signs of shock, plus the following:

- Severe thirst, restlessness, and air hunger.
- Bright frothy red blood coughed up indicates bleeding from the lung.
- Blood vomited like coffee grounds indicates bleeding in the area of the stomach.
- Rest the patient and secure medical aid speedily.

Control of Bleeding from Special Areas

Bleeding from the Nose. This can be serious if not stopped quickly. Sit patient with the head slightly forward. Loosen clothing around the neck, chest, and waist. Instruct the patient not to blow through the nose. Instruct the patient to breathe through the mouth. Apply pressure to flap of nostril for at least ten minutes. Apply cold packs or wet towels to neck, forehead, and bridge of nose.

Bleeding from Tooth Socket. Place a firm pad of gauze (not cotton or wool) over the socket and ask the patient to bite on it.

Bleeding from Palm of Hand.

- Place a dressing in the hand.
- Have the patient close hand firmly.
- Bandage the fist.
- Elevate in a triangular arm sling and rest the patient.

Note: The completion of the Basic First Aid Honor will satisfy this requirement. For the requirements of that honor, check the Pathfinder Honor Handbook.

RESOURCES

St. John Ambulance First Aid Manual; Red Cross First Aid Manual; Scout Handbook; Holiday Safety and First Aid Hints from Public Health Department.

METHOD OF TESTING

The instructor will give the examination.

Companion First Aid does not complete the First Aid Honor, nor is a certificate awarded.

ADVANCED REQUIREMENT 1

Build five different fires and describe their uses. Discuss the safety rules in lighting fires or hike eight kilometers (5 miles) and keep a log.

CLASS PERIODS: ONE

OBJECTIVE

1. To teach the use of fire to one's advantage such as warmth, protection, and food preparation.
2. To instruct that fire can be a friend as well as an enemy.

TEACHING METHOD

Select your fires and demonstrate in the out-of-doors. Have the Companions practice building their own fires.

1. Fire Building

Trench Fire. Dig a trench about 13 cm wide, sloping from ground level at the windward end to 13 cm wide and 17-22cm deep at the leeward (away-from-the-wind) end. Place five or six cross branches across trench to set pots and pans on for cooking. These cross branches should be wet or green. Trench fires are fine for windy places or areas of fire danger. But they flood quickly when it rains.



Hunter's Fire. Use two green slow-burning logs for sides. Line them up so the wind blows between them. Logs should be 33-35cm apart at the wide end, close enough at narrow end for the smaller size cooking pan. (Rocks may be substituted for green logs.)



Indian Fire. Start with a tepee. Add hardwood sticks in a criss-cross fashion around the tepee. This fire is simple and quick. It gives good ventilation and long-lasting coals.



Log Reflector Fire. Use green logs for the reflector. Plug mud in the cracks. Build fire on windward side of reflector so smoke will blow away from you. For cooking, rake out a bed of coals to cook over.



Rock Reflector Fire. Good heating fire. The rocks keep radiating heat as the fire dies. For best reflection, place rocks on three sides of fire. Or use a natural cliff face or bank.



Backlog Fire. Cozy council fire for a few campers - also good for heating. Use a big log or rock for the backlog. Lean several tepee fires against the backlog.



Log Cabin Fire. Best kind of fire for a large group to sit around. Build this solidly, not as a log cabin with a hollow room. Place tinder and kindling high. Light this fire near its top. This fire can be built large or small, depending on the size of your group.



Brush Fire. Cut brush into convenient lengths and pile pieces parallel. A parallel fire burns hotter and faster. Start with small tepee fire on windward side. Don't make the pile too large, and don't burn on a windy day.



2. Safety Rules

- a. Always check with a ranger or the forest service in the area where you plan to camp and learn the fire regulations. In different parts of the country the requirements vary, and equipment needed will vary accordingly. Some areas require fire permits. In such cases be sure you have a valid one.
- b. Always clear an area at least 3 meters in diameter of all leaves and other materials that might spread a fire.
- c. If the area has no fire regulations stating tools and equipment needed in case of emergency, one should at least have a shovel or trenching tool handy before a fire is started.
- d. Never build a fire under low-hanging branches of a tree.
- e. Keep the fire small. A huge fire accomplishes nothing except driving you away from it.
- f. Never play with fire such as making torches and swinging them around or stirring the fire so that hot ashes are carried by the wind into an area that might burn.
- g. When through using a fire, put it out. A fire is not out until you are sure the last spark has been drowned by water. Sprinkle water on the fire, do not pour it. Then stir the ashes and sprinkle more water on them until all the ashes are soaking wet. The Indians did not consider a fire out until they could put their hands into the ashes. If they could find no fire, they would place two dry sticks in a cross where the fire had been, indicating that the fire was out when they left. This is a good rule for Pathfinders.
- h. Never leave a fire unattended.
- i. Never build a fire in heavy wind.

The Report or Log Book should be written up as soon as possible after the hike or expedition while incidents are fresh and vivid in the mind. It should be an interesting and useful record of preparation and the actual journey. The opening section should set the scene and contain: title of group, party members, purpose of trip, dates, area, and author. The main part of the log should be the actual record of the day's activity including weather, campsites, food, type of country, outstanding landmarks, places to be avoided, animal and bird life, types of trees, shrubs, flowers, interesting incidents, party reactions,

use of equipment, maps, sketches, photos, etc. All log books should have a freehand sketch map of the route used including approximate scale, various land or sea marks, checkpoints, campsites, north point and date. The log book should include full equipment/clothing lists-comments on adequacy or lack of equipment and clothing, food lists-menus, suitability of meals, usefulness of first aid equipment, etc., tasks undertaken by party members and individual comments on member's expectations, reactions and feelings on the trip. Presentation should be in the form of a notebook, loose-leaf folder, photographic record, tape recording or other imaginative method.

METHOD OF TESTING

Discussion and participation.

ADVANCED REQUIREMENT 2

Cook a camp meal without utensils.

CLASS PERIODS: ONE

TEACHING METHOD

Not even aluminum foil is used. Below are some instructions on how and what to cook. This is a real "cooking fun" requirement for all.

Potatoes: Bring two or more potatoes. Get your firewood together. Scoop a shallow hole in the ground a little deeper than the thickness of your potatoes. If possible, line the bottom with flat stones. Start a fire in the hole and keep it going for half an hour. Now push the fire aside with a stick, place your potatoes in the hole, cover them with a layer of dirt or green leaves, and push the fire back over them. Put more wood on and keep your fire going for about an hour more. Test the potatoes in the coals by pushing a sharp stick into them. When the stick goes into the potatoes readily, they are done.

Kabob: Make a skewer from a straight stick, as long as your arm from elbow to fingertips, and as thick as a lead pencil. Sharpen the thinner end of the stick to a point. Peel an onion, cut it lengthwise through the middle, and separate the leaves. String onion alternately onto the stick with small tomatoes, pieces of gluten steaks, slices of cucumber, or pieces of green pepper. Broil next to the fire, turning repeatedly.

Vegetables: Carrots, beets, small turnips, and onions can be baked in the fire in the same way you do potatoes, keeping the fire going from fifty minutes to an hour.

You can even make baked tomatoes and apples that way if you wrap them in large green leaves and tie them around with strips of green bark from a thick stick.

Corn may be baked in the same manner in its own husks. Clean out the silk first. You can also dip corn in water, husks and all, and roast it on hot coals for about eight minutes, turning it occasionally. Or husk your corn, spear the ear on a stick, and hold it over the coals, turning slowly. Baked banana for dessert: rake coals over bananas. Bake until outside skin is charred. Open up, spread with butter and eat.

Camp Bread: Bring along a flour bag made from a piece of muslin. In this bag, keep prepared biscuit flour, or a mixture of 1 cup of ordinary flour, 1 teaspoon salt, and 1 teaspoon of shortening. To make the dough, poke a hole in the flour mixture right in the flour bag and pour in cup of water. With a stick, stir the water around, mixing the flour into it until a lump of rather stiff dough hangs onto the stick.

Ash Bread: The easiest way to bake your bread is to pat the dough into a loaf about 2 cm thick, sweep coals and ashes to one side, and place the dough directly on the ground where the fire was. Cover with grey ashes and rake back the fire on

top of it. After about ten minutes, test the baking by pushing a grass straw into the bread. If it comes out clean, the bread is done.

Twist: Cut a straight stick as long as a kabob stick, but as thick as two fingers. Point both ends. Peel it and dry it over the fire for a moment. Then grease it slightly. Shape the dough into a long sausage, as wide as two fingers and as thick as one finger. Twist it in a spiral around the stick. Push the stick in the ground, slanting over the hot coals. Regulate the baking by turning the stick in the ground and by pulling it out and pushing the other end into the ground until the twist is baked to a nice brown. Test with a grass straw as for ash bread.

Eggs in Onion Shells or Orange Cup: Onion shells are perfect containers for egg cooking. Scoop out half a large onion so that only about three outside leaf layers remain. Crack egg into shell, place it in coals. When cooked, remove outside onion layer.

Eggs Supreme: This is a good way of cooking eggs on a spit. With a knife point, pick a tiny hole in each end of egg. Push a thin green wood skewer through holes. Place on forks over coals. Cook ten minutes.

IMU (pronounced emoo): Dig a hole in the ground 1/2 meter square and 1/2 meter deep. Build a crisscross fire on a platform of split wood across hole. On the third layer of wood, place a layer of stones, one half brick size. Light and keep fire blazing for about one hour until the stones are almost at white heat and have fallen into the hole.

Now, working rapidly, shovel out burning pieces of wood and level stones and coals on the bottom of the hole. Throw in some vegetable tops or sweet leaves (wild grape, maple, sweet gum, sycamore) moistened with water. Place on the leaves large can protein for every four campers and, for each camper, 1 potato, 1 sweet potato, 1 carrot, 2 ears of corn, 1 green banana, and for dessert, 1 apple. Cover with more leaves, then close the hole with a heavy, wet burlap bag or gunny sack. Bury completely with dirt so that no steam can escape. After about two hours of cooking, open up your IMU carefully. Serve, and watch it disappear!

Flat Stone Cookery: Good picnic suppers may be cooked in this way. A flat stone should be carefully selected and placed upon four cornerstones. It should be carefully brushed, washed, and dried before any heat is placed near it. A good steady fire is then kindled and kept at a fairly equal temperature. Eggs and griddle cakes can be cooked all at the same time. A little shortening may be used to grease the "griddle."

ADVANCED REQUIREMENT 3

Prepare a knot board with at least fifteen different knots.

CLASS PERIODS: ONE

A good knot board should be at least 1 meter square and 1.25 cm thick. Plywood is a good material to use.

Have each participant make his own board. Square it perfectly, sand it well, do all lettering by wood burning and finish it the way he or she wishes.

Encourage the participants to complete the Knot Honor, which involves twenty-five different knots.

LIFESTYLE ENRICHMENT

REQUIREMENT 1

Complete one honor in Arts and Crafts not previously earned.

OBJECTIVE

To broaden the Companion's interests and develop personalized skills, which will instill a sense of accomplishment.

TEACHING METHOD

The requirements for all honors are found in the Pathfinder Honor Handbook. Notes on some specific honors may be available from the youth department of your local conference office.

Make the teaching of these honors as interesting as possible. When possible, visit an actual location or invite a specialist to come and talk to the group.

RESOURCE

Your local library will have books on many of the subjects you choose to study.

METHOD OF TESTING

The instructor must satisfy himself that the individual has met all requirements requested in the honor. The leader should forward a list of successful candidates to the local conference youth department, which will issue honor certificates.

Honor requirements correlating with school work can be credited if the junior obtains a signed agreement from the school that he has met the requirements.

ADVANCED REQUIREMENT 1

Complete one honor in Health and Science, Vocational, Household Arts, or Outdoor Industries not previously earned.

OBJECTIVE

To broaden the Companion's interests and abilities in those endeavors that are considered useful and practical or meet life's basic necessities.

TEACHING METHODS

The requirements for all honors are found in the Pathfinder Honor Handbook. Notes on some specific honors may be available from the youth department of your local conference office. Instructor helps are also appearing on the General Conference Youth Department website periodically. Check it out at www.gcyouthministries.org for this and much more.

Make the teaching of these honors as interesting as possible. When possible, visit an actual location or invite a specialist to come and talk to the group.

